



Sea-Bird Electronics, Inc.
1808 136th Place NE
Bellevue, WA 98005
USA

Phone: (425) 643-9866
Fax: (425) 643-9954
E-mail: seabird@seabird.com
Web: www.seabird.com

APPLICATION NOTE NO.45

Revised August 2006

Guide to SBE 32 Carousel Water Sampler Configuration Options

The SBE 32 Carousel Water Sampler is defined by the intended application(s) and control methods, as well as the Carousel model, number of and size of bottles, maximum depth rating, and connector type. Many of these configuration options interact; for example, the number of bottle positions and maximum bottle size is dependent on the Carousel model.

Consider the physical requirements of the intended application(s), the interface issues, and make the following choices:

- **CTD/Instrument to be used with the Carousel –**
 - SBE *9plus* CTD
 - SBE 19, *19plus*, or 25 CTD
 - SBE 49 CTD
 - SBE 50 Pressure Sensor
 - No CTD
- **Bottle closure control method –**
 - Real-time (bottles are closed by command from the ship, typically while monitoring real-time CTD data)
 - Autonomous (bottles are closed at pre-programmed pressures or times; no conducting wire is required)
- **Number of bottle positions -**
 - 12
 - 24
 - 36
- **Maximum bottle size (volume)**
 - Accommodates bottles from 1.2 to 30 liters, depending on Carousel model and number of bottle positions
- **Maximum depth rating -**
 - 6800 meters (22,300 ft)
 - 7000 meters (22,900 ft)
 - 10,500 meters (34,400 ft)
- **Bulkhead and cable connectors –**
 - Standard glass-reinforced epoxy
 - Wet-pluggable (MCBH)
- **Carousel model –**
 - Standard (SBE 32)
 - Compact (SBE 32C)
 - Sub-Compact (SBE 32SC)
- **Amount of flexibility –**
 - Design a system for one application
 - Design a system that can easily be reconfigured in the field to work with a variety of CTDs and bottle closure control methods

Each of these options is described in detail below.

CTD and Bottle Closure Control Method

Bottle Closure Control Method	Control	CTD / Instrument
Real-Time (bottles closed by command from the ship)	SBE 11 <i>plus</i> Deck Unit	SBE 9 <i>plus</i> CTD
	SBE 33 Deck Unit	SBE 19 / 19 <i>plus</i> / 25 CTD
		SBE 49 CTD (with limitations; see description below)
		None
Autonomous (no conducting wire required; bottles closed automatically based on pre-programmed pressures or times)	SBE 17 <i>plus</i> V2 SEARAM Recorder and Auto Fire Module	SBE 9 <i>plus</i> CTD
	Carousel Auto Fire Module (AFM)	SBE 19 / 19 <i>plus</i> / 25 CTD
		SBE 50 Pressure Sensor
		None

Each of these combinations is described below:

Real-Time Data Acquisition and Control (bottles closed by command from the ship)

- **SBE 11*plus* Deck Unit -**

The Carousel is designed to be connected directly to the **SBE 9*plus* CTD** and powered and controlled via the SBE 911*plus* modem channel. Bottles may be closed using the push-buttons on the SBE 11*plus*, or via the RS-232C modem connector on the back of the SBE 11*plus* while acquiring real-time data with SEASAVE (Sea-Bird real-time data acquisition software). The SBE 11*plus* includes a standard NMEA Interface to support NMEA 0183 protocol, and a standard interface for a Surface PAR sensor.

Note: The modem (Carousel command) channel is standard on the current production version of both the SBE 9*plus* and the SBE 11*plus* V2. It was optional on all 9*plus* CTDs with serial number 785 and lower, and on all 11*plus* Deck Units (V1 and V2) with serial number 700 and lower.

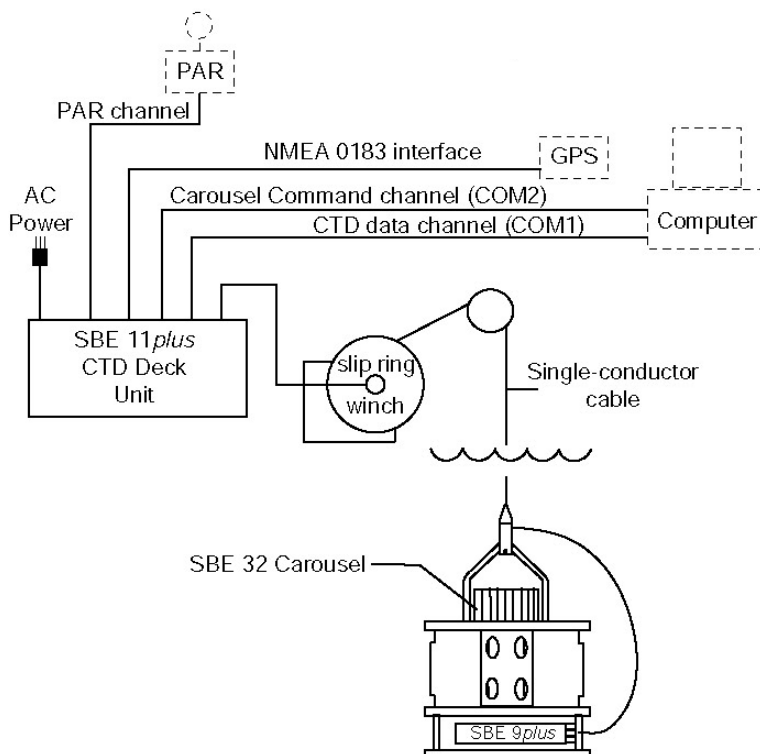

Real-Time Data Acquisition and Control *(continued)*

- **SBE 33 Carousel Deck Unit –**

With an optional interface, the Carousel can also be powered and controlled using the SBE 33, and can be used with or without a CTD (**SBE 19 / 19plus, 25, or 49 CTD**). The interface provides real-time data telemetry capability and surface power for these CTDs, and permits the control of the Carousel through the SBE 33 front panel controls or via SEASAVE.

When used **without a CTD**, bottles are closed with the SBE 33 front panel controls; depth determination must be approximated by monitoring the cable payout.

The SBE 33 has an optional NMEA Interface to support NMEA 0183 protocol, and an optional interface for a Surface PAR sensor.

Note: When using the SBE 49 CTD with the SBE 33, SEASAVE (our real-time data acquisition software) does not allow acquisition of NMEA or Surface PAR data.

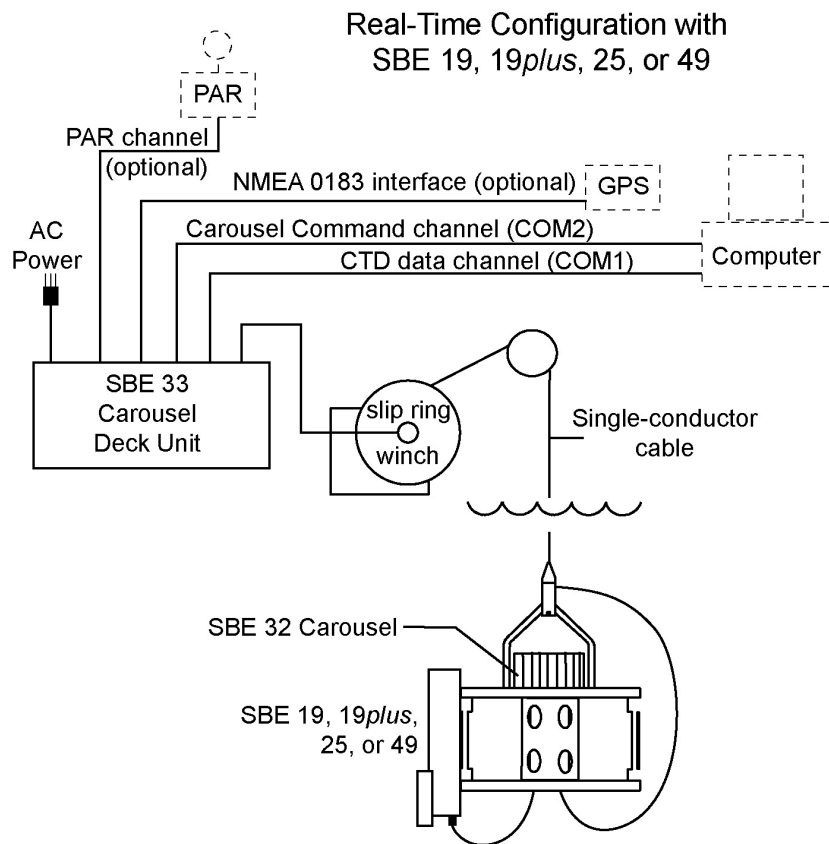

Autonomous Data Acquisition and Control (no conducting wire required; bottles closed automatically based on pre-programmed pressures or times)

Autonomous sampling does not provide water sample quality equal to real-time sampling; it is a compromise intended to serve users who do not have real-time capability on their vessel. See *Note on Water Sample Quality from Autonomous Samples* below.

- **SBE 17plus V2 SEARAM Recorder and Auto Fire Module -**

The SBE 17plus V2, mounted with the **SBE 9plus CTD**, allows the Carousel to operate autonomously on non-conducting cables. Using CTD pressure data from the 9plus and a programmable table of bottle closure pressures, the 17plus signals the Carousel to close bottles on upcast. Built-in logic and user-input parameters provide control in determining when the upcast begins, preventing accidental bottle closure caused by temporary upward movements during downcast. Power is supplied to the 9plus and Carousel by the 17plus' batteries, and data from the 9plus is stored in the 17plus memory.

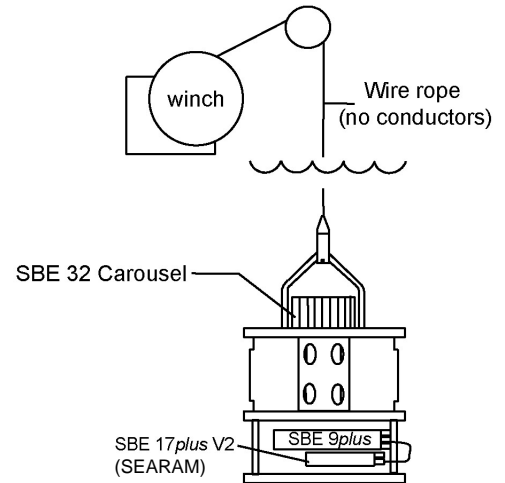

- **Carousel Auto Fire Module (AFM) -**

The AFM, mounted on or near the Carousel, allows the Carousel to operate autonomously on non-conducting cables, with or without a CTD.

Used **without a CTD**, the AFM is programmed to fire bottles at pre-defined intervals of elapsed time. The point at which samples are taken is determined (approximately) by monitoring cable payout and elapsed time.

Used with an **SBE 19, 19plus, or 25 CTD or SBE 50 Pressure Sensor**, the AFM monitors real-time pressure data transmitted by the CTD / SBE 50, and fires bottles at pre-defined pressures (depths) on upcast or downcast, or whenever the CTD / SBE 50 is stationary for a specified period of time. Power is supplied to the Carousel by the AFM's batteries; bottle number, firing confirmation, and five scans of CTD / SBE 50 data are recorded in the AFM memory for each bottle fired.

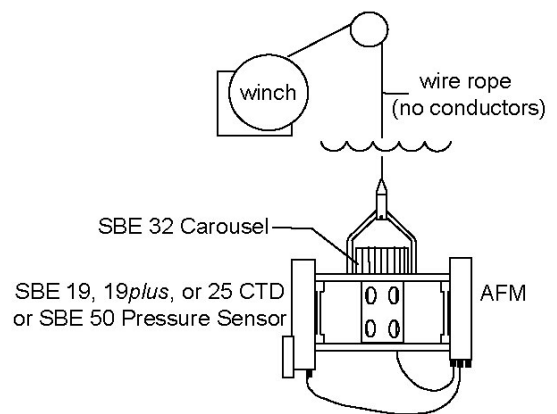

Note on Water Sample Quality from Autonomous Samples

The 17plus and AFM auto fire feature enables a ship without a slip ring and electro-mechanical cable to gather CTD data and collect water samples without the need for real-time CTD data. However, dynamic conditions affect the quality (validity) of water samples in several ways:

1. Oceanographic conditions (for example, internal waves and currents) cause density surfaces to move continuously, causing water of a given salinity to move up and down. Scientists generally prefer to view real-time CTD data on the downcast, to see the temperature/salinity/density structure. Then, on the upcast, they can stop the water sampler at depths where gradients are small, before closing each bottle; higher quality water samples are obtained, because dynamic errors are smaller.
2. If the CTD/water sampler package does not stop to fire a bottle, the water in the bottle is a mixture of water from many meters below the firing point (assuming you are taking water samples on upcast). If moving at 1 m/sec, a bottle's *flushing constant* is typically five to eight volumes, with water flushing slowly at the bottle inside wall and faster toward the bottle center. For a 5-liter bottle, the trapped sample contains a mix of water from a cylinder in the water column with diameter equal to the bottle inner diameter and volume of 25 - 40 liters (i.e., height of the cylinder is five to eight times the bottle height). Scientists prefer to stop the package to allow bottles to flush freely for several minutes before closing to obtain highest quality water samples.

The AFM (but not the 17plus) can be programmed to sample when stationary, eliminating the flushing problem (2). However, the lack of real-time data can still result in samples being taken in areas with large gradients (1), because the user can only estimate the depth of the gradients, **and** can only estimate the actual package depth from the cable payout.

While autonomous sampling can be a convenient alternative to real-time water sampler control, the quality of the samples is generally lower than for samples collected with a real-time system.

Number of Bottle Positions

Carousels are available for 12, 24, or 36 bottles, defining the number of lanyard release latches on the pylon, number of bottle mounts, and bottle mounting stand diameter. The 36-bottle Carousel is custom; consult Sea-Bird.

Maximum Bottle Size

The size (volume) of bottles to be used affects the bottle stand size. **Typically, a Carousel built for bottles of one size accommodates bottles of all smaller sizes (Exceptions: SBE 32 Standard Carousel built for 5-liter bottles does not accommodate 2.5-liter bottles; SBE 32 Standard Carousel and 32SC Sub-Compact Carousel built for 1.7-liter bottles does not accommodate 1.2-liter bottles).** Consider shipboard storage and handling space limitations, and try to anticipate the maximum bottle size that you will want. For example, if the immediate need is for twelve 5-liter bottles, but 10-liter bottles may be desired in the future, specify a twelve-position, 10-liter Carousel.

Housing Depth Rating and Connectors

The Carousel pressure housing is anodized aluminum, and has a depth rating of 6,800 meters (22,300 ft). Optional titanium pressure housings have depth ratings to 7000 or 10,500 meters (22,900 or 34,400 ft).

The Carousel is available with standard glass-reinforced epoxy or optional wet-pluggable (MCBH) connectors. Order the Carousel with connectors to match the type on the equipment (CTD, *17plus V2*, AFM as applicable) you will be connecting to it – interface cables have the same connector type on both ends.

All housing depth and connector options are available for all Carousel models (SBE 32, 32C, and 32SC).

Carousel Model

- **Standard** Carousel (SBE 32) – a 12-, 24-, or 36-position sampler (12-bottle Carousels for all bottle sizes through 30 liters; 24- and 36-bottle Carousels for bottles of 12-liter capacity and less). The SBE 32 includes a CTD extension stand for mounting an SBE *9plus*, 19, *19plus*, 25, or 49 CTD with auxiliary sensors and equipment (SBE *17plus V2*, transmissometer, fluorometer, etc.) in a horizontal position below the bottle stand.

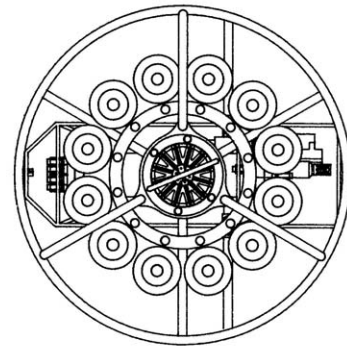

Note: Bottle mount stand height and diameter and CTD extension stand height varies, depending on number and size of bottles. See the SBE 32 specification sheet or manual for details.

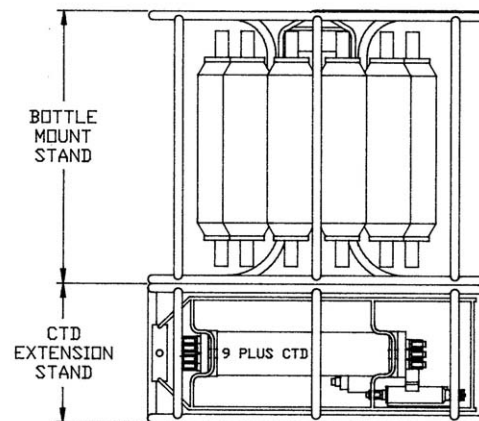

SBE 32 Standard Carousel (shown with SBE *9plus* CTD)

- Compact Carousel (SBE 32C)** - a 12-position sampler for 8-liter bottles. The bottle mount stand diameter is 2.5 cm (1 inch) smaller than for the comparable Standard Carousel, and the height is designed to fit through a 1 m x 1 m door. The 32C does not have an extension stand for mounting a CTD. To provide room for mounting a CTD and accessories (AFM, fluorometer, transmissometer, etc.), the bottle positions are closely spaced into two arcs, the centers of which are 180 degrees apart. This leaves four auxiliary mounting positions between the ends of the arcs for mounting a CTD and accessories. Because of the tight bottle spacing and smaller stand diameter, reversing thermometers would extend outside the bottle stand, and their use is not recommended.

 - An SBE 19, *19plus*, or 49 CTD mounts vertically in one of the auxiliary mounting positions, using an accessory mounting fixture.
 - Similarly, the SBE 25 CTD main housing mounts vertically in one of the auxiliary mounting positions. The SBE 25's standard modular sensors (SBE 3 Temperature Sensor, SBE 4 Conductivity Sensor, SBE 5 Pump, and SBE 29 Pressure Sensor) together mount vertically in a second auxiliary mounting position.
 - Auxiliary sensors and equipment (AFM, fluorometer, etc.) mount to any available auxiliary mounting positions.
 - A horizontal-mounting bracket for the SBE *9plus* CTD (with or without the SBE *17plus* V2) allows it to be mounted underneath and inside the bottle stand.
- Sub-Compact Carousel (SBE 32SC)** - a 12-position sampler for 1.7- or 2.5-liter bottles. The bottle mount stand diameter is 29 cm (11.5 inch) smaller than for the comparable Standard Carousel, and the height is designed to fit through a 1 m x 1 m door. The **32SC** does not have an extension stand for mounting a CTD. The SBE 32SC is designed for use with a SBE 19, *19plus*, or 25 CTD; it is not compatible with the SBE *9plus* CTD. To provide room for mounting a CTD and accessories (AFM, fluorometer, transmissometer, etc.), the bottle positions are closely spaced into two arcs, the centers of which are 180 degrees apart. This leaves four auxiliary mounting positions between the ends of the arcs for mounting a CTD and accessories. Because of the tight bottle spacing and smaller stand diameter, reversing thermometers would extend outside the bottle stand, and their use is not recommended.

 - An SBE 19, *19plus*, or 49 CTD mounts vertically in one of the auxiliary mounting positions, using an accessory mounting fixture.
 - Similarly, the SBE 25 CTD main housing mounts vertically in one of the auxiliary mounting positions. The SBE 25's standard modular sensors (SBE 3 Temperature Sensor, SBE 4 Conductivity Sensor, SBE 5 Pump, and SBE 29 Pressure Sensor) together mount vertically in a second auxiliary mounting position.
 - Auxiliary sensors and equipment (AFM, fluorometer, etc.) mount to any available auxiliary mounting positions.

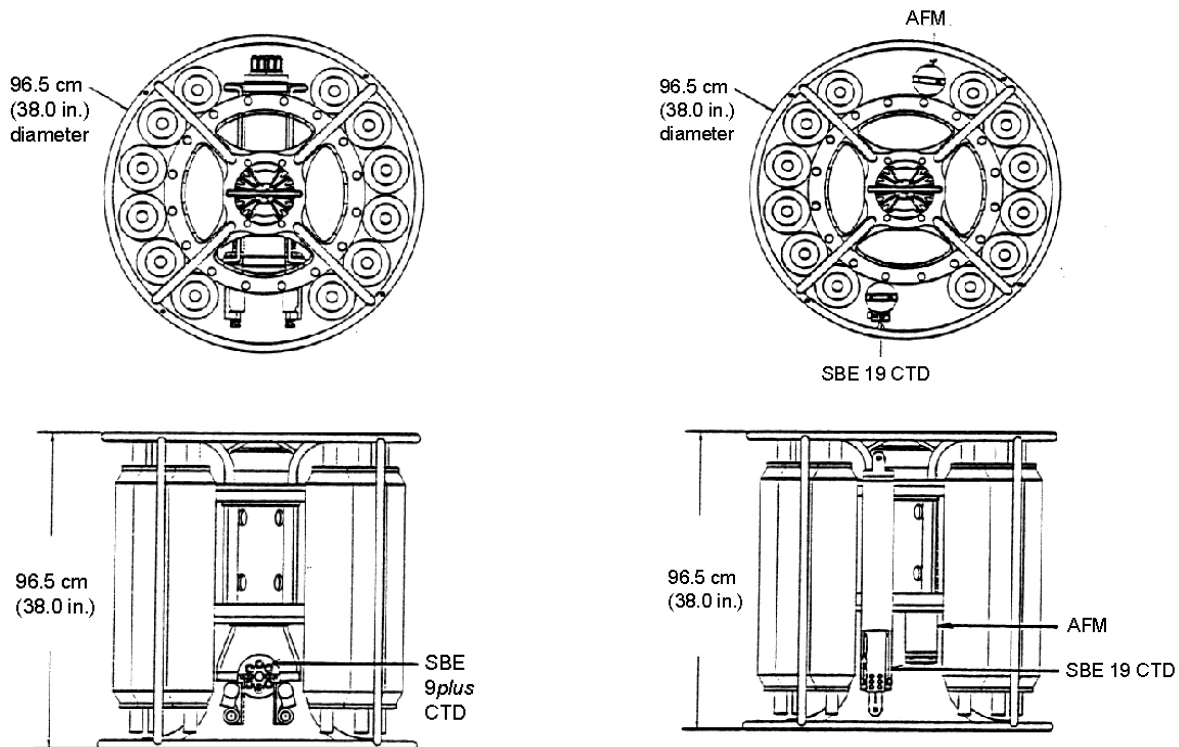

SBE 32C Compact Carousel (shown with SBE *9plus* CTD)

SBE 32C Compact Carousel (shown with SBE 19 CTD);
SBE 32SC Sub-Compact Carousel similar
 [diameter= 70 cm (27.5 in.), height = 79 or 99 cm (31 or 39 in.)]

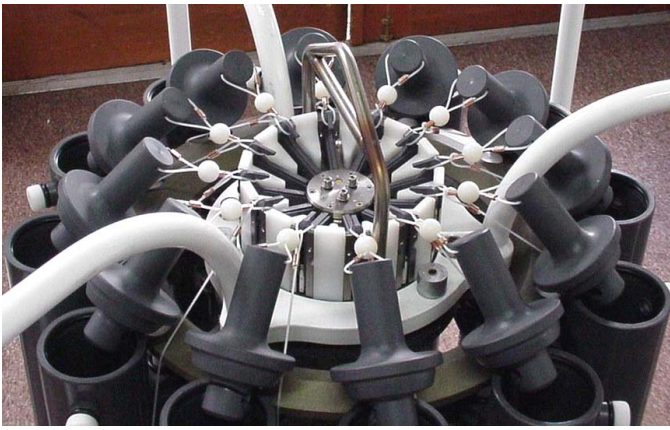

Standard Pylon Detail

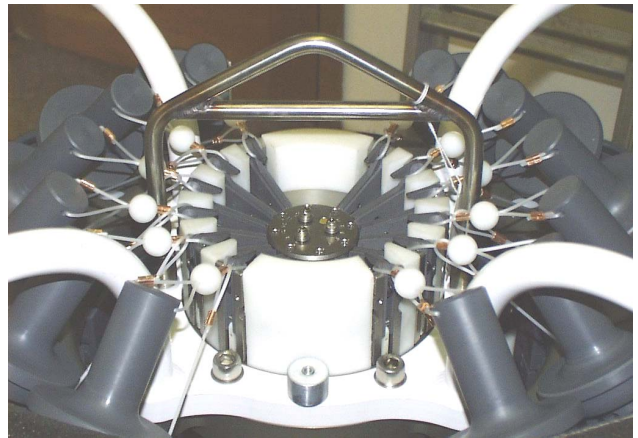

Compact or Sub-Compact Pylon Detail

Note: As shown above, the latch spacing in the Standard Carousel pylon is different from the spacing in the Compact or Sub-Compact Carousel. This difference prevents substitution of the Standard Carousel pylon in the Compact or Sub-Compact Carousel, or vice versa, because the angle of the lanyards (which connect the latches to the bottles) will prevent proper functioning of the system.

Designing a Flexible System

Looking at the chart on the following page, there are six application types:

1. Real-time with SBE 9*plus* CTD and SBE 11*plus* Deck Unit
2. Real-time with SBE 19, 19*plus*, 25, or 49 CTD and SBE 33 Deck Unit
3. Real-time with no CTD and SBE 33 Deck Unit
4. Autonomous with SBE 9*plus* CTD and SBE 17*plus* V2 SEARAM
5. Autonomous with SBE 19, 19*plus*, or 25 CTD, or SBE 50 Pressure Sensor, and AFM
6. Autonomous with AFM and no CTD

All application types can be accommodated by ordering an SBE 32 (Standard model) with operating mode option 32-3b (standard connectors) or 32-3e (wet-pluggable connectors) or an SBE 32C (Compact model) with operating mode option 32C-3b (standard connectors) or 32C-3d (wet-pluggable connectors). These provide a system with the most flexibility, allowing you to easily swap equipment at sea as needed for the application.

Application types 2, 3, 5, and 6 can be accommodated by ordering an SBE 32SC (Sub-Compact model) with operating mode option 32SC-3a (standard connectors) or 32SC-3c (wet-pluggable connectors).

Chart for Determining Appropriate Model & Optional Operating Mode Configuration

Operation	CTD/ Instrument	Control	Carousel Model	Bottle Positions	Bottle Size (liters)	Carousel Operating Mode Option ¹	
Real-Time (bottles closed by command from ship)	SBE 9plus ²	SBE 11plus Deck Unit	32	12	1.7, 2.5, 5, 8, 10, 12, 20, or 30	None required (also works with 32-3b or 32-3e)	
				24	1.7, 2.5, 5, 8, 10, or 12		
				36	(consult Sea-Bird)		
				32C	12	8	None required (also works with 32C-3b or 32C-3d)
	SBE 19, 19plus, 25, or 49	SBE 33 Deck Unit	32		12	1.7, 2.5, 5, 8, 10, 12, 20, or 30	32-3b or 32-3e
					24	1.7, 2.5, 5, 8, 10, or 12	
					36	(consult Sea-Bird)	
				32C	12	8	32C-3b or 32C-3d
				32SC	12	1.7 or 2.5	32SC-3a or 32SC-3c
	None	SBE 33 Deck Unit	32		12	1.7, 2.5, 5, 8, 10, 12, 20, or 30	32-3b or 32-3e
					24	1.7, 2.5, 5, 8, 10, or 12	
					36	(consult Sea-Bird)	
			32C	12	8	32C-3b or 32C-3d	
			32SC	12	1.7 or 2.5	32SC-3a or 32SC-3c	
Autonomous (no conducting wire required; bottles closed automatically based on pre-programmed pressures or times)	SBE 9plus ²	SBE 17plus V2 SEARAM	32	12	1.7, 2.5, 5, 8, 10, 12, 20, or 30	None required (also works with 32-3b or 32-3e)	
				24	1.7, 2.5, 5, 8, 10, or 12		
				36	(consult Sea-Bird)		
				32C	12	8	None required (also works with 32C-3b or 32C-3d)
	SBE 19, 19plus, or 25, or SBE 50 Pressure Sensor	Carousel Auto Fire Module (AFM)	32		12	1.7, 2.5, 5, 8, 10, 12, 20, or 30	None required (also works with 32-3b or 32-3e)
					24	1.7, 2.5, 5, 8, 10, or 12	
					36	(consult Sea-Bird)	
				32C	12	8	None required (also works with 32C-3b or 32C-3d)
				32SC	12	1.7 or 2.5	None required (also works with 32SC-3a or 32SC-3c)
	None	Carousel Auto Fire Module (AFM)	32		12	1.7, 2.5, 5, 8, 10, 12, 20, or 30	None required (also works with 32-3b or 32-3e)
					24	1.7, 2.5, 5, 8, 10, or 12	
					36	(consult Sea-Bird)	
			32C	12	8	None required (also works with 32C-3b or 32C-3d)	
			32SC	12	1.7 or 2.5	None required (also works with 32SC-3a or 32SC-3c)	

Notes:

¹ Listed operating mode options are for the Carousel electronics only. CTDs/Instruments (SBE 19, 19plus, 25, 49 CTD; SBE 50 Pressure Sensor) and controllers (SBE 11plus, SBE 33, SBE 17plus V2, AFM) are not included; order separately.

² The SBE 32SC's (Sub-Compact) standard telemetry is compatible with the SBE 9plus, but the SBE 9plus is too large to allow a practical mounting in the SBE 32SC frame.