



SEA-BIRD ELECTRONICS, INC.

1808 136th Place N.E., Bellevue, Washington 98005 USA
Telephone: (425) 643-9866 Telex: 292915 SBEI UR
Fax: (425) 643-9954 email: seabird@seabird.com

DATE	SYM	REVISION RECORD	AUTH	DR	CHK
12.99	A	Changed Rod length from 12" to 16"	MJ	CB	
04.06	D	Change nuts to all 1/2-13 Stainless.	MJ	CB	

SBE P/N 90162

SBE 9 Rosette Clamp Assembly

KIT CONTENTS

SBE P/N	Manufacturer P/N	Primary SBE Application	QTY
23590C	SBE 9 Rosette Clamp, Coated	Main Sensor Mount Brackets	1
30409	Teflon Tape	Provides Electrical Insulation between dissimilar metals	6 ft.
31061	Rod, 1/2-13 Threaded, 16" SS	Support bars for Rosette Clamp to Cage guard	4

HARDWARE

SBE P/N	Part Description	Primary SBE Application	QTY
23601	Screw Insul, 5/16 x .50"	Used with Rosette Clamp Securing Bolts	8
23602	Screw Insul, 1/2" x .20"	Insulate between threaded rod and Cage Guard holes	8
23603	Screw Insul, 1/2" x .50"	Insulate between threaded rod and Rosette Clamp holes	8
30231	Nut, 1/2-13 Hex SS	Securing Nuts for internal connections on threaded rod	16
30259	Washer, 1/2" Flat, Narrow	Used with Securing Nuts for all places on threaded rod	16
30561	Bolt, 5/16-24 x 1-3/4 Hex	Rosette Clamp Securing Bolts	4
30562	Nut, 5/16-24 Nylon Stop	Used with Rosette Clamp Securing Bolts	4

The Rosette Mount Clamp will allow the customer to vertically install an SBE 9plus CTD onto a Rosette Style Carousel Frame.

SBE 9plus Installation into Clamp

A. Install Teflon Tape onto Clamps

1. A liner of Teflon tape is necessary to provide electrical insulation between dissimilar metals.
2. Clean the inner radius of each Rosette Clamp (23590C) with alcohol, or other mild solvent.
3. If available, apply a glue primer such as DC-1200 to the inner surfaces, and allow to dry according to instructions on the can.
4. Apply a layer of Teflon tape that covers the entire inside of each clamp. You may need to use 2 pieces per clamp.
5. If enough tape is available, it may be advisable to use a double layer of tape.

B. Secure Clamp Around 9plus

1. Clamps are symmetrical, and as such may install in either direction around the 9plus.
2. Position clamps 1/4" away from the 9plus Top Endcap, so that TC sensor pair face the far end.
3. Secure Clamp around 9plus with 4 bolts (30561), 4 nuts (30562), 8 insulators (23601)
 - a. Insulators install first, filling the screw holes.
 - b. Apply heavy coat of NeverSeez to the bolts, and secure the assembly fairly tight.
 - c. *You need it to be tight, but you do not want to crush the insulators.*
4. *Plumbing should not interfere with the clamp, nor should the clamp interfere with the plumbing. Any plumbing may be redone to an extent in order to better route the water flow.*

Parent Part Number: 90162

SBE Drawings:

67058B SBE 9plus Rosette Clamp
Installation

Sea-Bird Electronics Procedure

PROCEDURE NUMBER: **67058**

TITLE: **SBE 9plus Rosette Clamp Kit**

REVISION: **D**

EFFECTIVE DATE: **04/07/2006**

CHECKED BY:

PAGE 1 of 1



SEA-BIRD ELECTRONICS, INC.

1808 136th Place N.E., Bellevue, Washington 98005 USA
Telephone: (425) 643-9866 Telex: 292915 SBEI UR
Fax: (425) 643-9954 email: seabird@seabird.com

C. Install Threaded Rods.

1. Thread 1 nut (30231) a few inches onto the end of each rod, and follow with 1 washer (30259).
2. Install insulators (23603) onto each side of all four holes in the clamp.
3. Feed rod through the clamp. You want at least 1" slack, preferably more.
4. Apply NeverSeez and install a 2nd flat washer (30259) and a lock nut (30219) onto the end of each rod as it feeds through the clamp.
5. Apply NeverSeez to the other clamp interface, and tighten the inner nut down against the clamp.
You may need to thread the nut farther up first, in order to apply the NeverSeez.

Clamped 9plus Installation into Rosette Carousel Frame

A. Install Hardware

1. Thread 1 nut (30231) over each rod, a few inches, and follow with 1 flat washer (30259).
2. Install insulators (23602) onto both sides of all four holes in the guard.

B. Install 9plus

1. Slide 9plus into position from below, so that all four rods are feeding through the frame.
2. Apply NeverSeez to the ends of all 4 rods before install nuts.
3. Secure each rod with 1 flat washer (30259) and 1 lock nut (30219).
4. Tighten the lock nuts just until rods begin to poke out through the other side.
5. Adjust the nuts as needed so that the 9plus is seated vertically in the cage.
6. Apply NeverSeez to inner interface area, and tighten the interior nuts against the frame.
7. You want the nuts tight, but you do not want to crush the insulators.

Parent Part Number: 90162

SBE Drawings:

67058B SBE 9plus Rosette Clamp
Installation

Sea-Bird Electronics Procedure

PROCEDURE NUMBER: **67058**

TITLE: **SBE 9plus Rosette Clamp Kit**

REVISION: **D**

EFFECTIVE DATE: **04/07/2006**

CHECKED BY:

PAGE 1 of 1

DATE	SYM	REVISION RECORD	AUTH.	DR.	CK.
12.99	A	Changed Rod to 16"	MJ	CB	
04.06	B	Change PN of Nuts	MJ	CB	

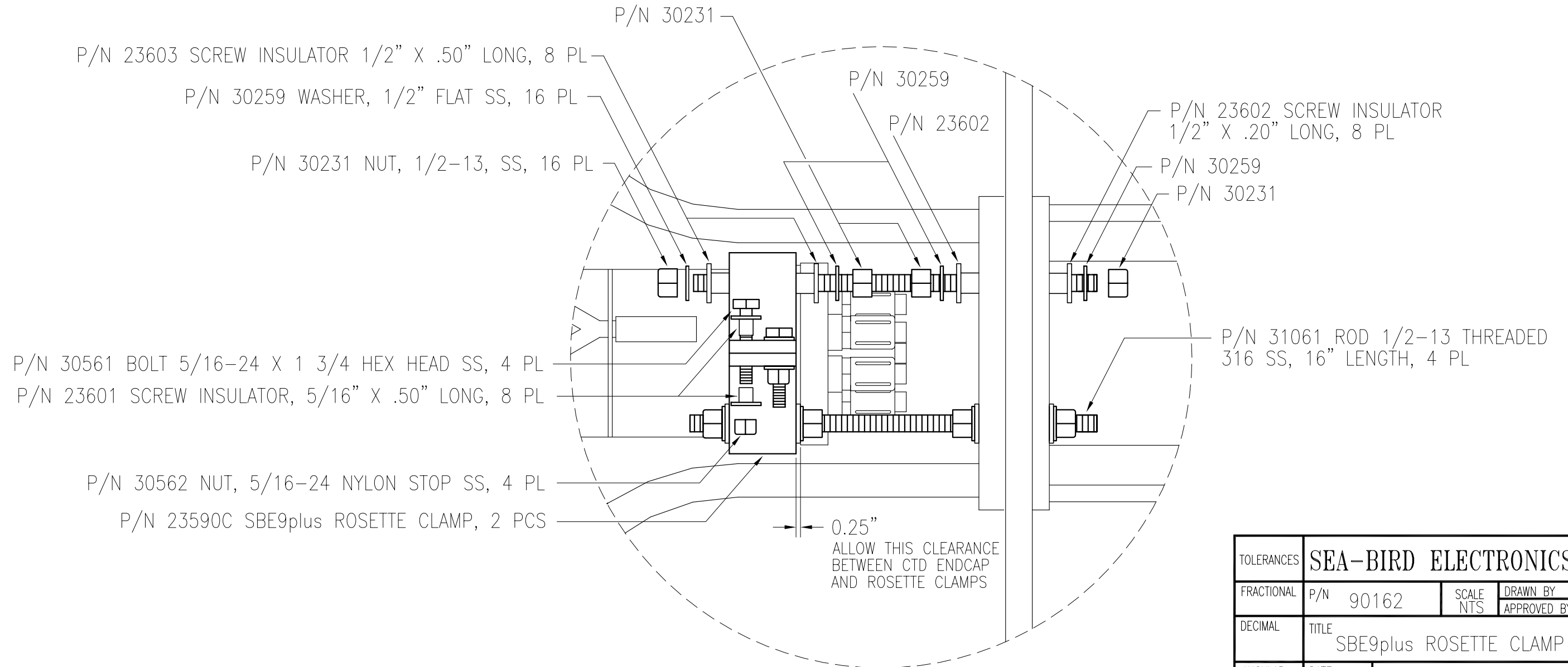
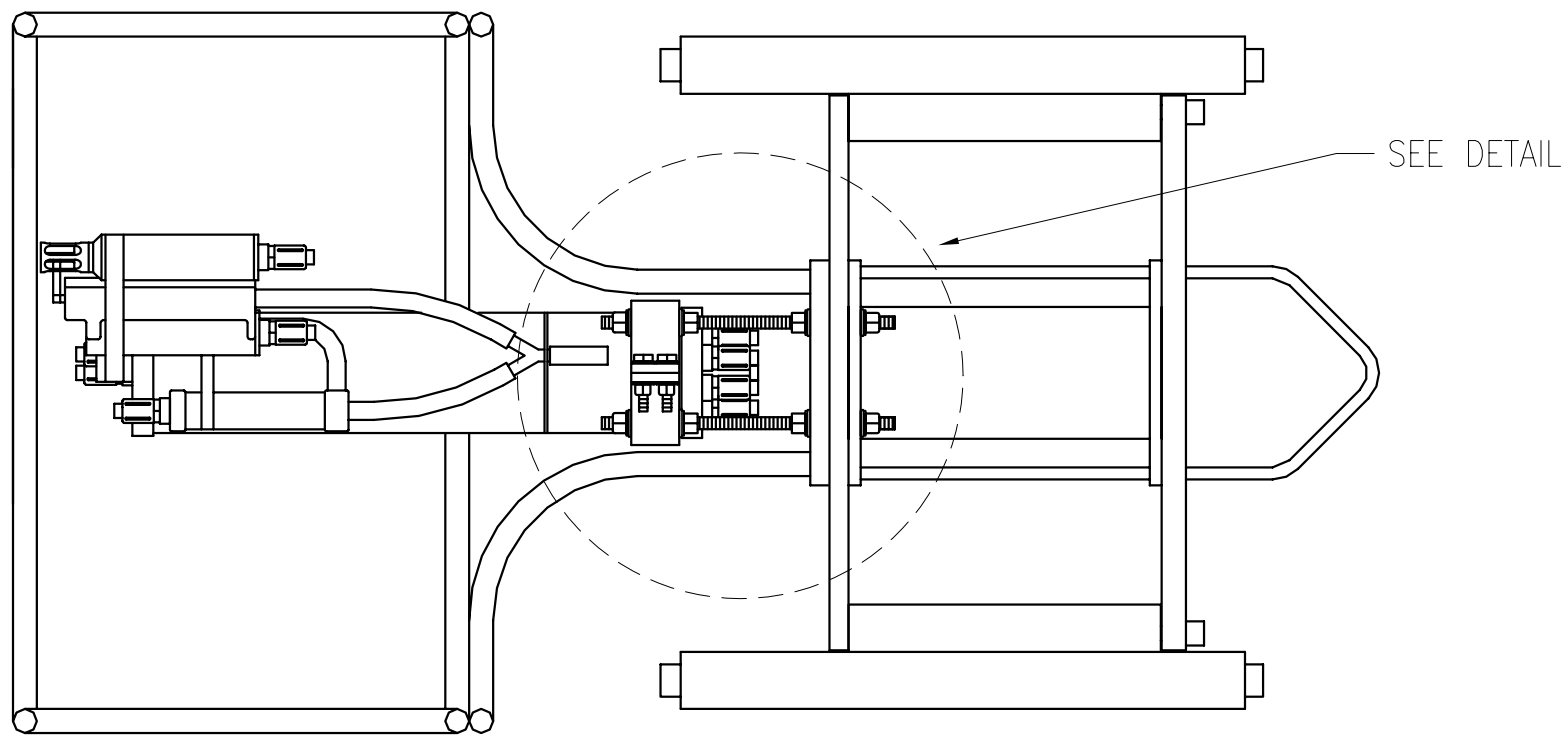

TOLERANCES	SEA-BIRD ELECTRONICS, INC				
FRACTIONAL	P/N 90162	SCALE NTS	DRAWN BY CEG		
DECIMAL	TITLE SBE9plus ROSETTE CLAMP ASSY				
ANGULAR	DATE 8.11.99	DRAWING NUMBER	67058	REV B	