



1808 136th Place N.E., Bellevue, Washington 98005 USA

Telephone: (425) 643-9866 Telex: 292915 SBEI UR

Fax: (425) 643-9954

email: seabird@seabird.com

DATE	REV	REVISION RECORD	AUTH	DR	CHK
6.03	B	Removed More Nylon Stop Nuts	PL	MJ	
1.04	C	Added 30257, 30377, 30570		KLP	
7.25.05	D	Updated quantities	KHH	KLP	CB
3.8.06	E	Procedure included incorrect drawing	AD	MJ	CB

SBE P/N 50115, 50115A

## SBE 1.375" frame Carousel Frame Assembly Kit

### KIT CONTENTS

SBE P/N	Description	Primary SBE Application	QTY
231421	Rod, 1/2-13 Threaded, 18"	Secure and tighten Plates together	4
23714	SBE 32 Cage U-Bolt	Interface Extension Stand to Lower Guard	6
23715	SBE 32 Cage Flange	Interface Extension Stand to Lower Guard	6
23723C	SBE 24 Place Lifting Bail	Lifting Bail for Carousel	1
23922	SBE 32 Large Bail Insulator	Bail to Lower hub / Adapter Plate	4
23923	SBE 32 Large Bail Insulator	Bail to Upper hub / Adapter Plate	2
30044	Seacat Anode, 1"	6 used on plates, 6 used on guards, 2 used on extension stand	14
30409	Teflon Tape	Used on all strapping, and contact points of U bolts and flanges	4'
30666	Blue Moly	Used on all threaded hardware to prevent seizing of metal on metal	1 can

### HARDWARE

SBE P/N	Description	Primary SBE Application	QTY
30210	Nut, 3/8-16 nylon stop	Extension stand U-Bolts; 1 on CTD bolt (30195)	12
30231	Nut, 1/2-13 Hex	18 on hub and guard bolts; 8 on threaded rod	34
30257	Washer, 3/8" flat, SS, 7/8" OD max	Used with U-bolts	12
30259	Washer, 1/2" flat/narrow	2 on each Hub/Plate/Guard bolt (30603, 30612); 8 on Rods	46
30594	Washer, 1/2" split ring	1 on each Hub/Plate/Guard bolt (30603, 30612); 8 on Rods	34
30603	Screw, 1/2-13 x 3-1/2" Socket	hub to guard securing bolts	6
30611	Mach screw, 3/8-16 x 2" FH	Side bar securing screws	12
30612	Mach screw, 1/2-13 x 2-1/2"	Hub to Plate securing bolts	12
30615	Washer, 3/4" flat, SS	Used on Lifting Bail	4
30616	Washer, 3/4" Split ring lock	Used on Lifting Bail	4
30620	Nut, 3/4-10 NC Hex, SS	Used on Lifting Bail	4

### Kits:

SBE P/N	Description	Primary SBE Application	QTY
50199	Extension Stand CTD Installation Kit	Contains parts to mount a cage to the extension stand	1
50296	Deck Pad Kit	Contains parts to attach deck pads to frame	1

### SBE Drawings:

- 40697 SBE32 24 position Lifting Bail Detail
- 40713 SBE32 1/375" Frame Assembly
- 40714 Carousel Frame Parts Table
- 67117 Deck Pad Assembly

### Sea-Bird Electronics Procedure

PROCEDURE NUMBER: 67079

TITLE: SBE32- PN50115, 1.375in Frame Assembly Kit

REVISION: E

EFFECTIVE DATE: 03-08-2006

CHECKED BY: \_\_\_\_\_ PAGE 1 of 5

**APPLICATIONS:***Accessory Parts*

SBE P/N	Part Description	Primary SBE Application	QTY
30044	Zinc Anode, 1"	3 on each adapter plate, 3 on each frame guard, 2 on ext. stand	14
30409	Teflon Tape	Wrap 8" around each position where a U-Bolt will go	4 feet
30666	Blue Moly NeverSeez	Apply liberally to ALL threaded areas that receive nuts	1 can

*Bottom Plate to Lower Guard*

SBE P/N	Part Description	Primary SBE Application	QTY
30259	Washer, 1/2" Flat/narrow	1 above plate, 1 below guard	12
30594	Washer, 1/2" split ring lock	1 below guard	6
30231	Nut, 1/2-13 Hex	1 below guard	6
30603	Cap Screw, 1/2-13 x 3-1/2" Socket Head	Secure lower plate to frame, outer ring, alternate with rods	6

*Hub to Adapter Plates*

SBE P/N	Part Description	Primary SBE Application	QTY
30231	Nut, 1/2-13 Hex	Pylon hub to top & bottom guards, 1 per bolt	12
30259	Washer, 1/2" flat/narrow	2 per bolt from hub to bottom plate; 1 per bolt from top plate to hub	18
30594	Washer, 1/2" split ring	1 on each Hub to Plate bolt	12
30612	Screw, 1/2-13 x 2-1/2" Socket	Adapter plates to hub	12

*Top Guard to Lower Guard*

SBE P/N	Part Description	Primary SBE Application	QTY
231421	Rod, 1/2-13, 18" length	Secure Outer ring on Plates together	4
30259	Washer, 1/2" Flat/narrow	16 used on rods	16
30594	Washer, 1/2" split ring lock	16 on rods	16
30231	Nut, 1/2-13 Hex	16 on rods	16
30611	Screw, 3/8-16 x 2" FH, SS, CS	Side pars, 2 per bar	12

*Pylon Lifting Bail*

SBE P/N	Part Description	Primary SBE Application	QTY
23723C	SBE 24 Place Lifting Bail	Lifting Bail for Carousel	1
23922	SBE 32 Large Bail Insulator	Bail to Lower hub / Adapter Plate	4
23923	SBE 32 Large Bail Insulator	Bail to Upper hub / Adapter Plate	2
30615	Washer, 3/4" flat, SS	Use at each lower hub insulator interface	4
30616	Washer, 3/4" Split ring lock	Use between flat washer and stop nut	4
30620	Nut, 3/4-10 NC Hex, SS	Above adapter plate to provide extra tension Below to secure in place	4

*Extension Stand*

SBE P/N	Part Description	Primary SBE Application	QTY
23714	SBE 32 Cage U-Bolt	Interface Extension Stand to Lower Guard	6
23715	SBE 32 Cage Flange	Interface Extension Stand to Lower Guard	6
30210	Nut, 3/8-16 nylon stop	Extension stand U-Bolts	12
30257	Washer, 3/8 flat	Extension stand U-Bolts	12
30409	Teflon Tape	Wrap 8" around each position where a U-Bolt will go	4 feet

SBE Drawings:

40697 SBE32 24 position Lifting Bail Detail  
 40713 SBE32 1/375" Frame Assembly  
 40714 Carousel Frame Parts Table  
 67117 Deck Pad Assembly

**Sea-Bird Electronics Procedure**

PROCEDURE NUMBER: 67079

TITLE: SBE32- PN50115, 1.375in Frame Assembly Kit

REVISION: E

EFFECTIVE DATE: 03-08-2006

CHECKED BY: \_\_\_\_\_ PAGE 2 of 5

**Note on Prep Work**

1. Many parts for the extension stand may already be installed.
2. All of the anodes may be installed.
3. Deck pads are installed.
4. Lifting bail assembly will not be installed on the hub, but the bail insulators may be installed.
5. All screws need a liberal amount of Blue Molly/Never Seez applied before installation.

**Carousel Frame Final Assembly**

*Refer to SBE Assembly drawing for details*

1. Clear off a large enough space, and cover the floor with carpet or cardboard to protect the paint on the frame.
2. Assemble the frame according to following instructions.

**A. Install and secure lower plate onto lower guard.**

1. Set the lower frame on 2x4's to allow access for hardware installation.
  - a. Brace the frame on no less than 4 equally spaces blocks to prevent tipping.
2. Install the bottom plate to the lower guard so that all the pins are facing up.
  - a. Align it so that the 2 largest holes on the plate are lined up with the same size holes on guard. (these are for the lifting bail that is installed later)
3. Secure with 6 bolts (30603), 12 flat washers (30259), 6 lock washers (30594), and 6 nuts (30231).
  - a. From the top-put each bolt through one flat washer then through the carousel frame, a second flat washer, a lock washer and finally the nut.
  - b. Positioning of the bolts goes:
    - *large hole – bolt – empty hole – bolt – empty hole – bolt – large hole (around both ways)*
    - *For more clarification see the drawing.*

**B. Install and secure Hub (with pylon removed).**

1. The end of the hub with the most holes installs towards the top.
2. Secure the hub to the bottom plate with 6 bolts (30612), 12 flat washers (30259), 6 lock washers (30594), and 6 nuts (30231).
  - a. From the top-put each bolt through one flat washer then through the hub and bottom plate, a second flat washer, a lock washer and finally the nut.

**C. Install and secure upper Plate.**

1. Install top plate so that the curved edge of outer ring is on top.
2. Line up the plate so that the large holes line up over the large holes in the lower plate.
3. Secure the top plate to the hub with 6 bolts (30612), 6 flat washers (30259), 6 lock washers (30594), and 6 nuts (30231).
  - a. From the top-put each bolt through the top plate and hub, a flat washer, a lock washer and finally the nut.

SBE Drawings:

40697 SBE32 24 position Lifting Bail Detail  
40713 SBE32 1/375" Frame Assembly  
40714 Carousel Frame Parts Table  
67117 Deck Pad Assembly

**Sea-Bird Electronics Procedure**

PROCEDURE NUMBER: 67079

TITLE: **SBE32- PN50115, 1.375in Frame Assembly Kit**

REVISION: E

EFFECTIVE DATE: 03-08-2006

CHECKED BY: \_\_\_\_\_ PAGE 3 of 5

**D. Install and secure upper guard.**

1. Install the upper guard over the top plate.
2. Line up the large holes with the large holes in the plate.
3. Secure to the lower guard directly with the threaded rods.
  - a. Slide the threaded ring through the upper guard and top plate.
  - b. Thread a nut (30231) far enough up the threaded rod that the top of the rod can be removed from the top plate and guard.
  - c. Then place a lock washer (30594) and a flat washer (30259) (in that order) onto the bottom of the threaded rod before inserting it into the hole in the bottom plate.
  - d. Thread a nut, a lock washer, and a flat washer onto the top of the threaded rod. Move them far enough down the threaded rod that the top of the rod will once again be above the upper guard when it is through the hole.
  - e. Put the top of the threaded rod through the hole in the top guard and plate.
  - f. Thread a flat washer, lock washer, and nut onto the top and bottom of the rod. (as they come through the plates/guards).
    - *The lock washer always goes against the nut.*
  - g. Repeat for the other three threaded rods.
    - *Do not tighten the nuts down at this time.*
4. The side bars are secured to upper and lower guards with 1 bolt (30611) on each end.
  - a. There are two different styles of side bars one has 1 arc on each end the other has 1 arc on one end and a double arc on the other.
  - b. The 3 bars with single arcs on both ends line up under the three bars on the upper guard.
    - *The arced area goes over the outside of the carousel guard frame.*
  - c. The other 3 bars go in the remaining places, with the double arc end attached to the upper guard.
5. Tighten down the hardware on the threaded rods.

**E. Install lifting bail (kit 50115 only).**

1. Install the two large 1.85" bail insulator (23923) from the top into the large holes in the upper guard/top plate.
  - a. The flange will rest on the top.
2. Install the four 1.2" bail insulator (23922) into the large holes in the bottom plate/lower guard.
  - a. Two go in from the top, the other two from the bottom.
3. Insert the two legs of the lifting bail into the upper bail insulators.
4. Thread on a nut (20620), a lock washer (30616), and a flat washer (30615) (in that order) onto each leg of the lift bail.
  - a. Thread these up far enough that the spacers on the top of the lifting bail are sitting on the surface of the upper bail insulators.
5. Feed the legs of the lift bail through the bottom plate and lower guard.
6. On the bottom of the lift bail install a flat washer, a lock washer, and a nut. Tighten these down.
7. Tighten down the nuts on the top of the bottom plate.
  - a. The nuts should be tightened down on the top and bottom of the bottom plate/lower guard.

SBE Drawings:

40697 SBE32 24 position Lifting Bail Detail  
40713 SBE32 1/375" Frame Assembly  
40714 Carousel Frame Parts Table  
67117 Deck Pad Assembly

**Sea-Bird Electronics Procedure**

PROCEDURE NUMBER: 67079

TITLE: SBE32- PN50115, 1.375in Frame Assembly Kit

REVISION: E

EFFECTIVE DATE: 03-08-2006

CHECKED BY: \_\_\_\_\_ PAGE 4 of 5

**F. Install CTD cage into extension stand per drawing 40683.**

1. Place the extension stand, deck pad side down, onto the floor.
2. The CTD and cage installs into the frame per drawing 40683 with pre-installed hardware.
  - a. You will need to remove the hardware and use it to install the cage.
3. Any external sensors may be mounted later for safety, or now for convenience.

**G. Install the carousel onto extension stand per assembly drawing 40713.**

1. Wrap the top bar of the extension stand with 1" wide Teflon tape (pn 30409).
  - a. Six (6) locations total evenly spread out around the extension stand.
  - b. Wrap each location 2-3 times.
2. Use a winch to lift the carousel and set it on the extension frame.
  - a. If a winch is not available have 4 or more people lift the carousel and set it on the extension frame.
  - b. Line up the support bars with the extension stand uprights.
3. Wrap the surface of the lower guard with 1" wide Teflon tape corresponding to the tape on the extension stand.
4. Secure each location with one u-bolt, one cage flange, two washers (30257), and two nuts (30210).
  - a. Place the u-bolt over the lower guard then the extension frame, then place the cage flange over both legs of the u-bolt; one washer and one nut, in that order, are placed over each leg of the u-bolt and tightened down.

SBE Drawings:

**40697** SBE32 24 position Lifting Bail Detail  
**40713** SBE32 1/375" Frame Assembly  
**40714** Carousel Frame Parts Table  
**67117** Deck Pad Assembly

**Sea-Bird Electronics Procedure**

PROCEDURE NUMBER: **67079**

TITLE: **SBE32- PN50115, 1.375in Frame Assembly Kit**

REVISION: **E**

EFFECTIVE DATE: **03-08-2006**

CHECKED BY: \_\_\_\_\_ PAGE 5 of 5

DATE	SYM	REVISION RECORD	AUTH.	DR.	CK.
2/95	A	NYLON BAIL INSULATORS	PG	DG	
1/98	B	CHANGED THREADED ROD SPEC	RMB		
5/99	C	ADDED LOCK WASHERS TO HUB	MJ		
12.01	D	REMOVED LOCK NUTS	MJ		

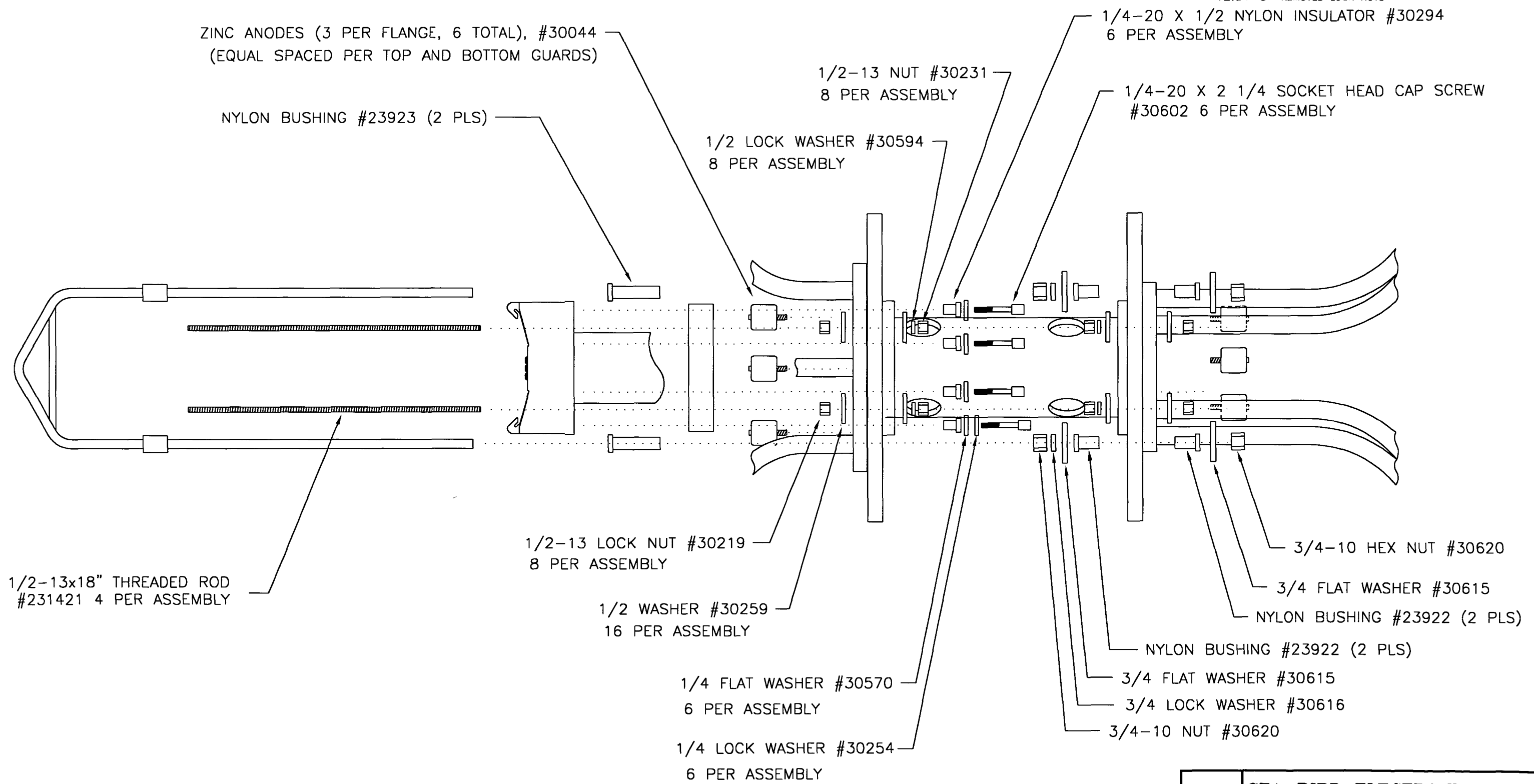

NOTE: APPLY THREAD ANTI-SEIZE TO ALL THREADED HARDWARE PRIOR TO ASSEMBLY.

TOLERANCES	SEA-BIRD ELECTRONICS, INC				
FRACTIONAL	P/N	SCALE	DRAWN BY DJM		
DECIMAL	TITLE SBE 32 PYLON AND LIFTING BAIL DETAIL 24 PLACE				
ANGULAR	DATE 1/27/94	DRAWING NUMBER 40697			REV D

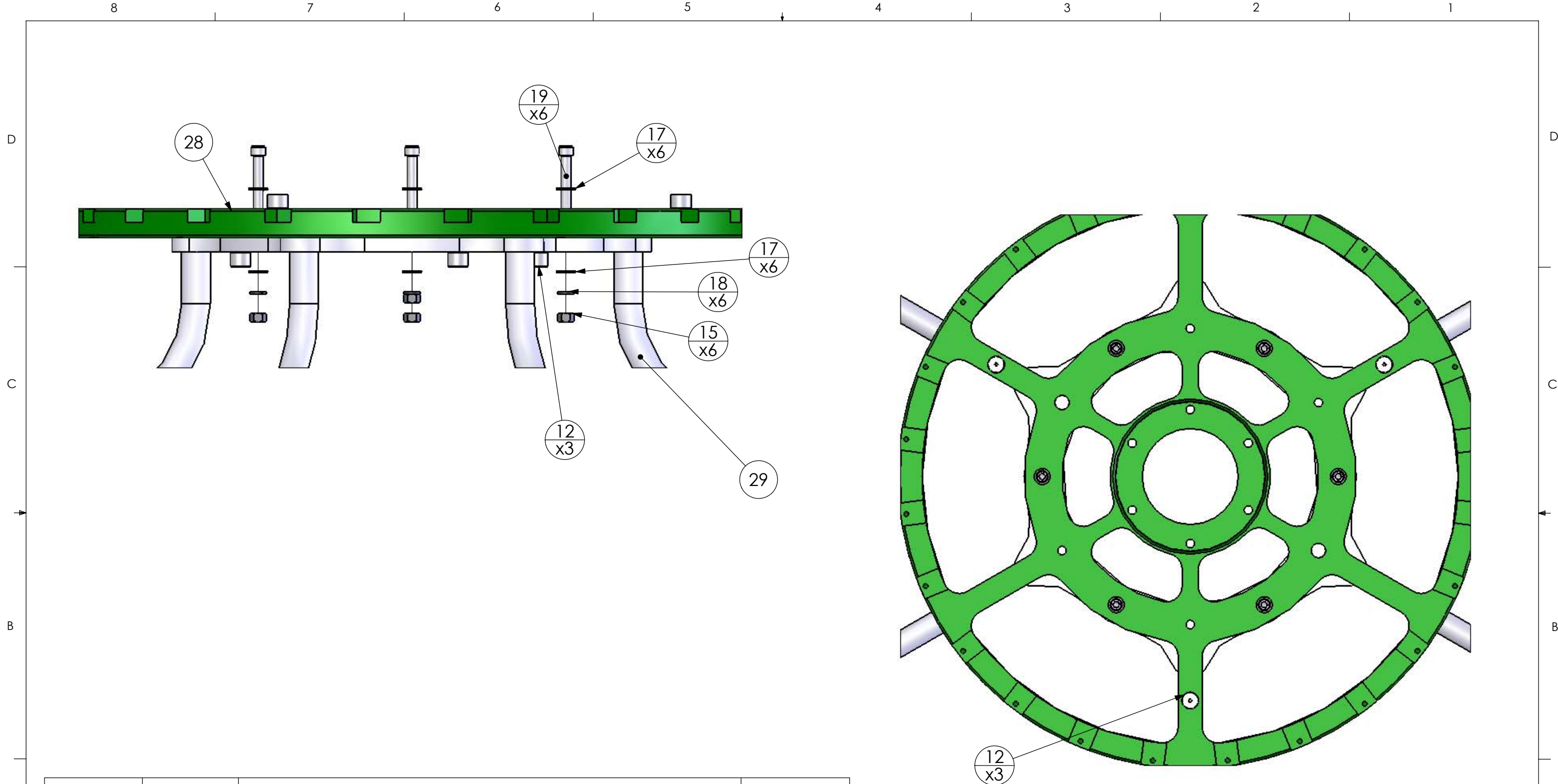

ITEM NO.	PN	DESCRIPTION	Default/QTY.
10	23922	SBE-32 LARGE BAIL INSULATOR	4
12	30044	SEACAT ANODE, 1" DIA., G1050	12
15	30231	NUT, 1/2-13 HEX, SS	34
17	30259	WASHER, 1/2" FLAT/NARROW, AN960C816L, SS	46
18	30594	WASHER, 1/2" SPLIT RING LOCK, SS	34
19	30603	CAP SCREW, 1/2-13 X 3-1/2" SOCKET HEAD, SS	6
28	VARIES	SB3-32 BOTTOM ADAPTER PLATE	1
29	VARIES	SBE32 CAROUSEL 24 PLACE LOWER GUARD	1

UNLESS OTHERWISE SPECIFIED:		NAME	DATE	SEA-BIRD ELECTRONICS, INC.	
DIMENSIONS ARE IN INCHES		DRAWN	7/29/05	1808 - 136th PLACE NE, BELLEVUE, WA 98005	
TOLERANCES:		PROPRIETARY AND CONFIDENTIAL		425-643-9866	
FRACTIONAL ±		THE INFORMATION CONTAINED IN THIS DRAWING IS THE SOLE PROPERTY OF SEA-BIRD ELECTRONICS, INC. ANY REPRODUCTION IN PART OR AS A WHOLE WITHOUT THE WRITTEN PERMISSION OF SEA-BIRD ELECTRONICS, INC. IS PROHIBITED.		TITLE:	
ANGULAR: ± 2		MATERIAL		1.375" frame, Universal Assembly	
BEND ±		#		P/N: none	
TYP RAD .015		FINISH		SIZE DWG. NO. REV	
.XX ± .01		N/A		B 40713D	
.XXX ± .005		DO NOT SCALE DRAWING		SCALE: 1:2	
MACHINED SURFACES		Old Part/Draw Info		SHEET 1 OF 4	
INTERPRET GEOMETRIC TOLERANCING PER: ANSI Y14.5M - 1994		N/A /N/A			

REVISIONS				
ZONE	REV.	DESCRIPTION	DATE	APPROVED
	-			

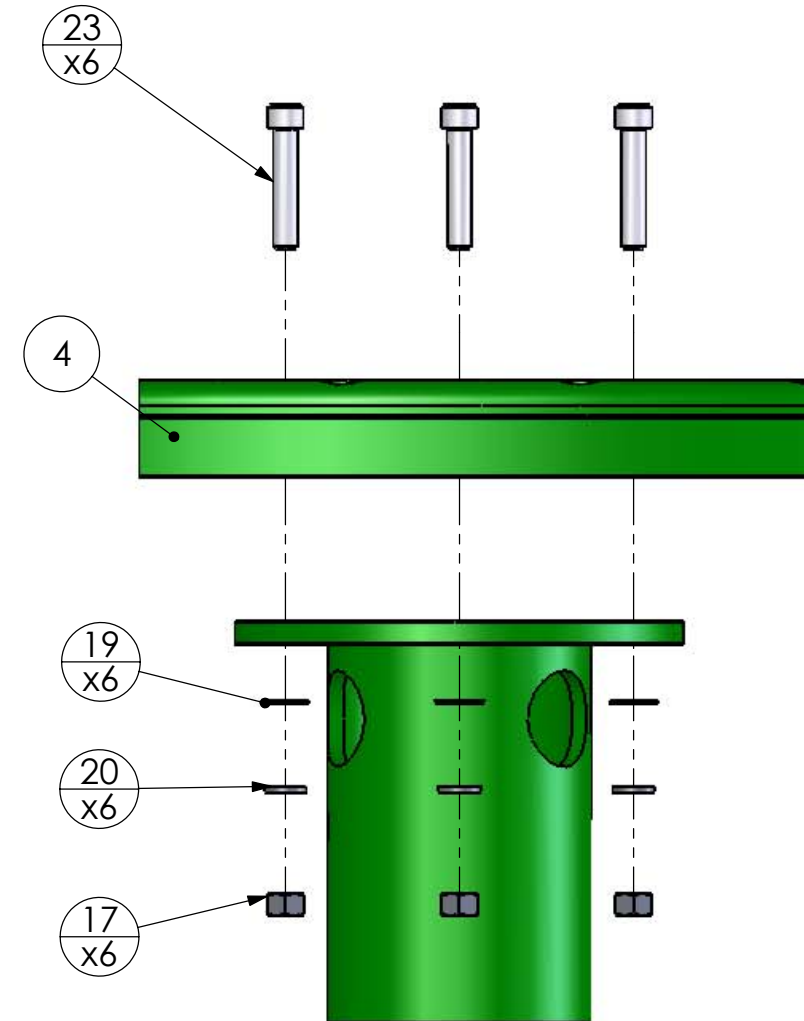
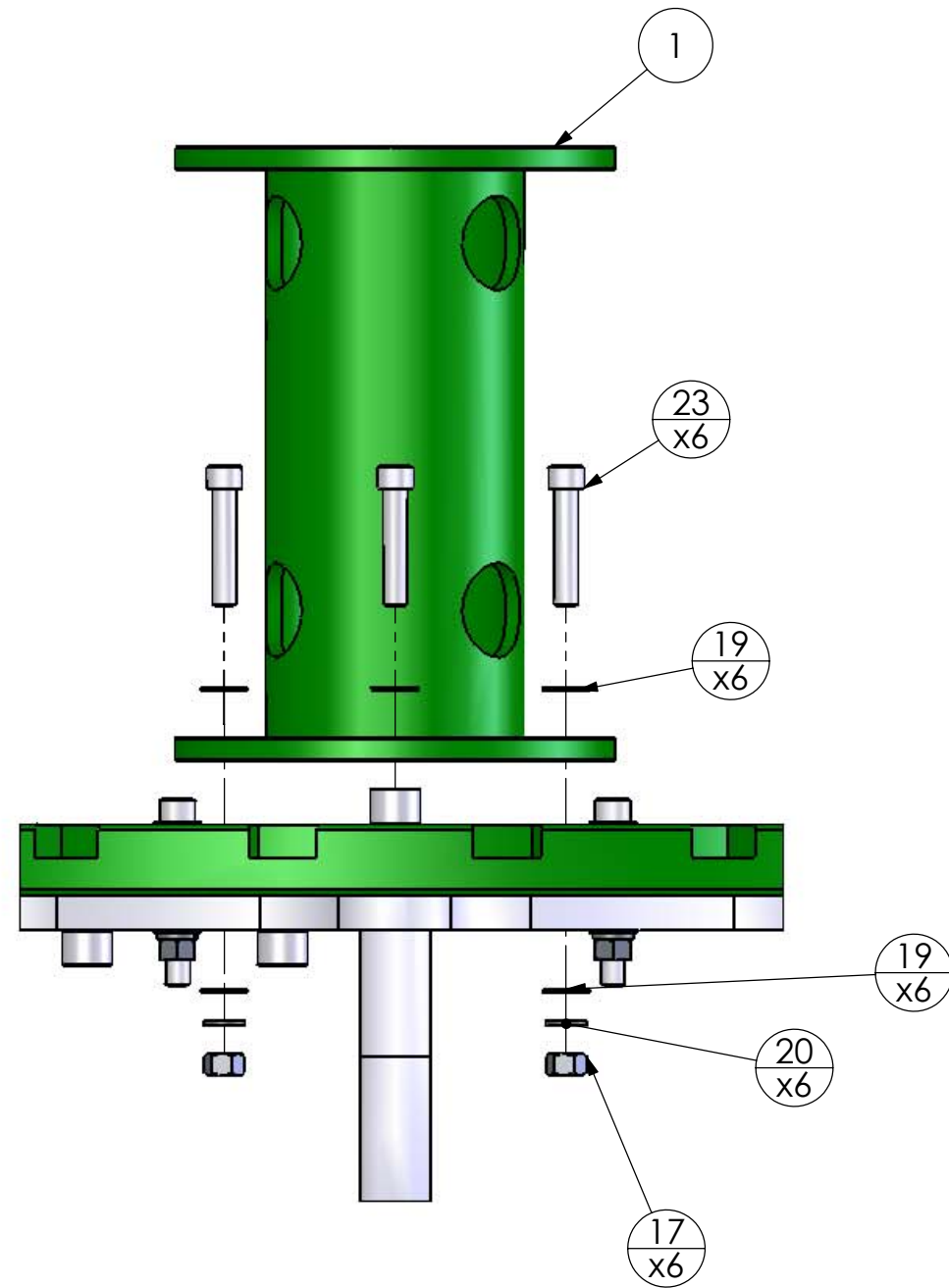

ITEM NO.	PART NUMBER	DESCRIPTION	Default/QTY.
1	23668	SBE32 HUB	1
4	23716	SBE-32 TOP ADAPTER PLATE	1
17	30231	NUT, 1/2-13 HEX, SS	34
19	30259	WASHER, 1/2" FLAT/NARROW, AN960C816L, SS	46
20	30594	WASHER, 1/2" SPLIT RING LOCK, SS	34
23	30612	CAP SCREW, 1/2-13 X 2-1/2" SOCKET HEAD, SS	12
27	50199	SBE9plus Carousel Mount Kit	1

UNLESS OTHERWISE SPECIFIED: DIMENSIONS ARE IN INCHES TOLERANCES: FRACTIONAL ± ANGULAR: ± 2 BEND ± .XX ± .01 TYP RAD .015 .XXX ± .005 MACHINED SURFACES INTERPRET GEOMETRIC TOLERANCING PER: ANSI Y14.5M - 1994		NAME klp	DATE 7/29/05	SEA-BIRD ELECTRONICS, INC. 1808 - 136th PLACE NE, BELLEVUE, WA 98005 425-643-9866 TITLE: 1.375" frame, Universal Assembly P/N: none
MATERIAL #		PROPRIETARY AND CONFIDENTIAL THE INFORMATION CONTAINED IN THIS DRAWING IS THE SOLE PROPERTY OF SEA-BIRD ELECTRONICS, INC. ANY REPRODUCTION IN PART OR AS A WHOLE WITHOUT THE WRITTEN PERMISSION OF SEA-BIRD ELECTRONICS, INC. IS PROHIBITED.		
FINISH N/A		COMMENTS: DEBUR AND BREAK SHARP EDGES Old Part/Draw Info N/A /N/A		SIZE B
DO NOT SCALE DRAWING		DWG. NO. 40713D		REV
		SCALE: 1:2		SHEET 2 OF 4



8 7 6 5 4 3 2 1

REVISIONS				
ZONE	REV.	DESCRIPTION	DATE	APPROVED
	-			

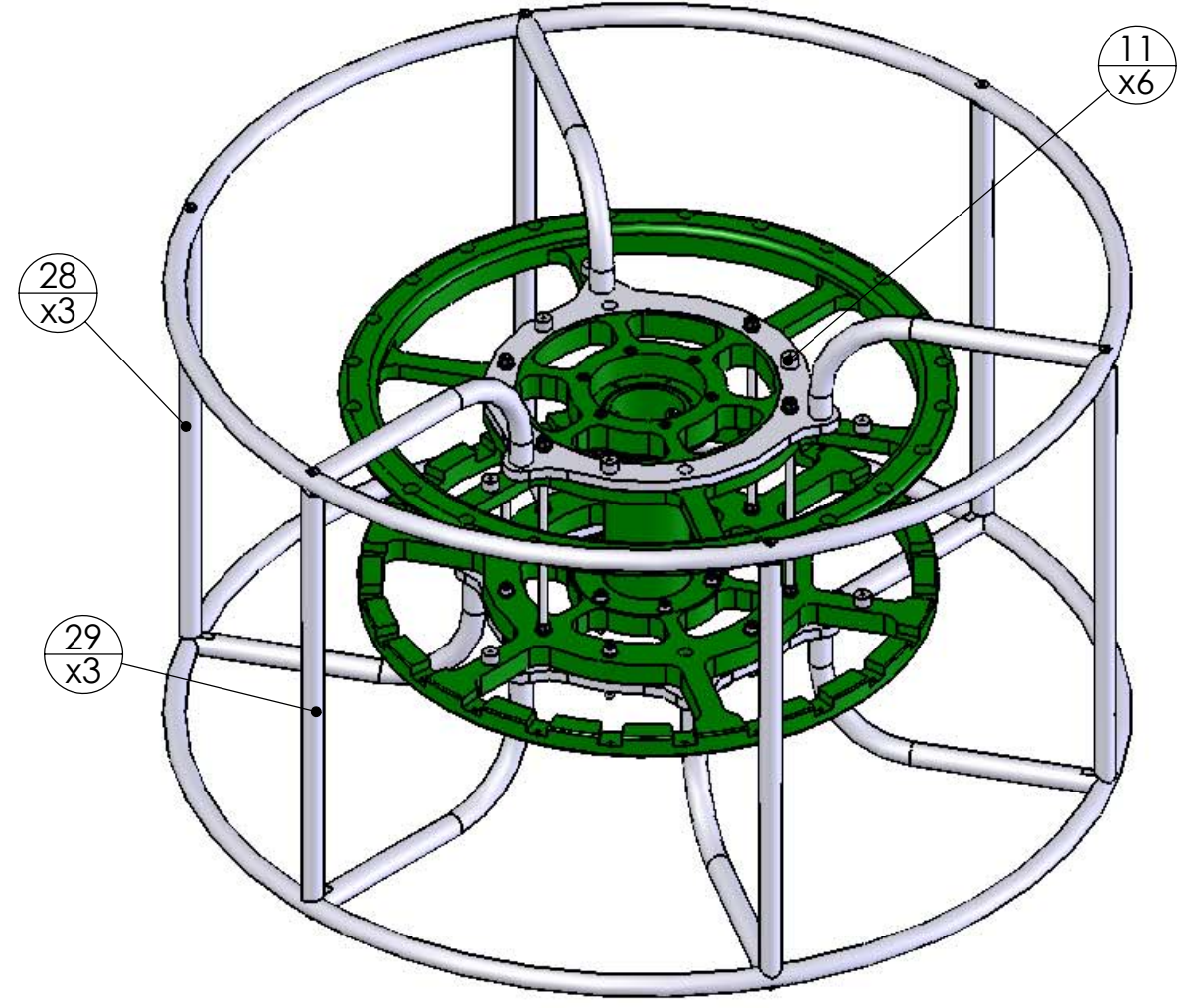
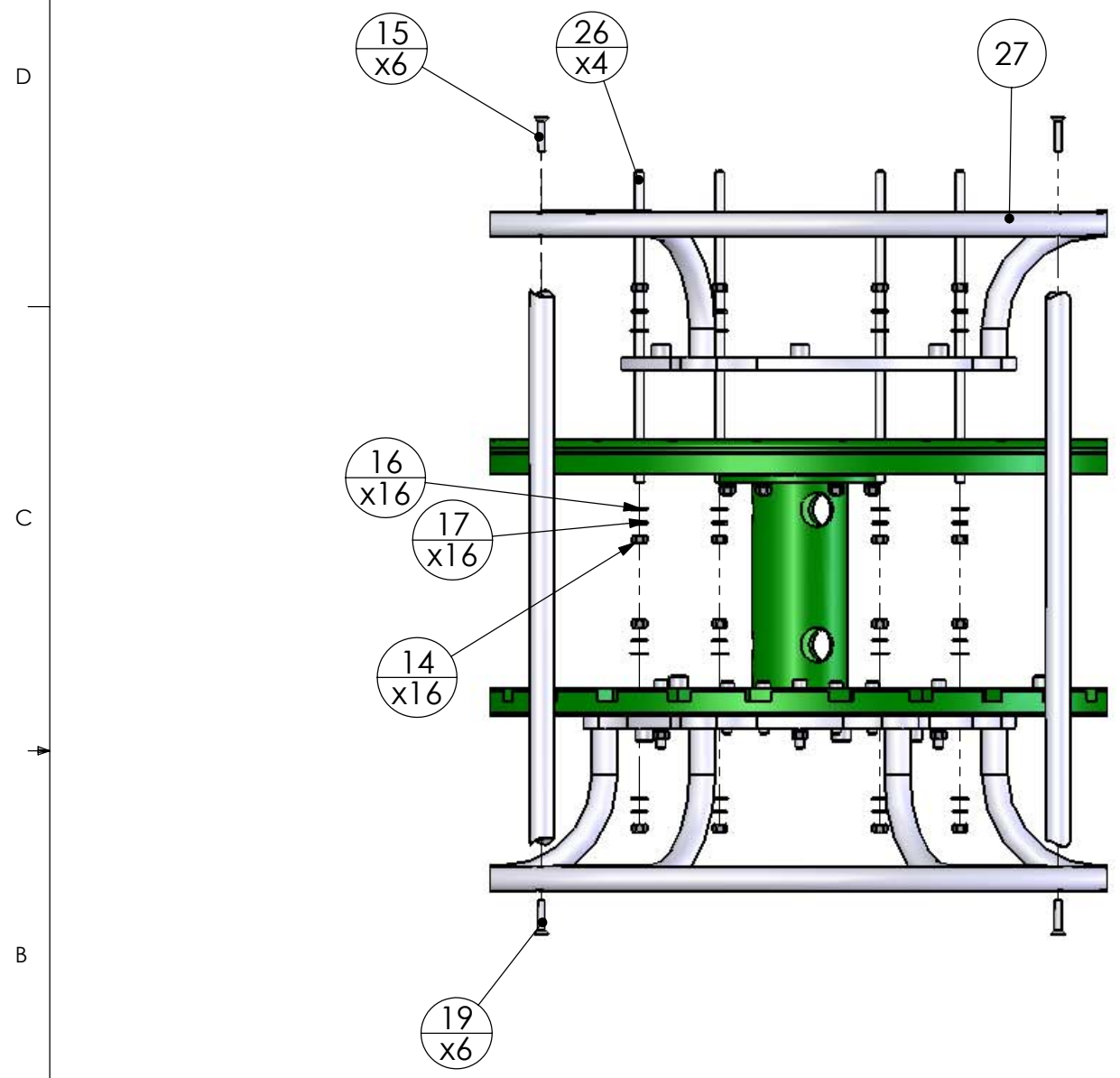

ITEM NO.	PART NUMBER	DESCRIPTION	Default/QTY.	top guard/QTY.
11	30044	SEACAT ANODE, 1" DIA., G1050	12	12
14	30231	NUT, 1/2-13 HEX, SS	34	34
16	30259	WASHER, 1/2" FLAT/NARROW, AN960C816L, SS	46	46
17	30594	WASHER, 1/2" SPLIT RING LOCK, SS	34	34
19	30611	3/8-16 X 2" FLAT HEAD SOCKET, SS	12	12
26	231421	ROD, 1/2-13 THREADED 18" LENGTH, SS	4	4
27	VARIES	SBE32 CAROUSEL 1.375" FRAME UPPER GUARD	1	1
28	VARIES	SBE32 CAROUSEL 1.375" FRAME GUARD SIDE BAR 1	3	3
29	VARIES	SBE32 CAROUSEL 1.375" FRAME GUARD SIDE BAR 2	3	3

UNLESS OTHERWISE SPECIFIED:  
 DIMENSIONS ARE IN INCHES  
 TOLERANCES:  
 FRACTIONAL ±  
 ANGULAR: ± 2 BEND ±  
 .XX ± .01 TYP RAD .015  
 .XXX ± .005  
 MACHINED SURFACES  
 INTERPRET GEOMETRIC  
 TOLERANCING PER:  
 ANSI Y14.5M - 1994  
 MATERIAL  
 #  
 FINISH N/A  
 DO NOT SCALE DRAWING

NAME	DATE
klp	7/29/05
DRAWN	
PROPRIETARY AND CONFIDENTIAL	
THE INFORMATION CONTAINED IN THIS DRAWING IS THE SOLE PROPERTY OF SEA-BIRD ELECTRONICS, INC. ANY REPRODUCTION IN PART OR AS A WHOLE WITHOUT THE WRITTEN PERMISSION OF SEA-BIRD ELECTRONICS, INC. IS PROHIBITED.	
COMMENTS:	
DEBUR AND BREAK SHARP EDGES	
Old Part/Draw Info	
N/A	/N/A

SEA-BIRD ELECTRONICS, INC.  
 1808 - 136th PLACE NE, BELLEVUE, WA 98005  
 425-643-9866  
 TITLE:  
 1.375" frame, Universal Assembly  
 P/N: none  
 SIZE DWG. NO. REV  
**B** 40713D  
 SCALE: 1:2 SHEET 3 OF 4

8 7 6 5 4 3 2 1

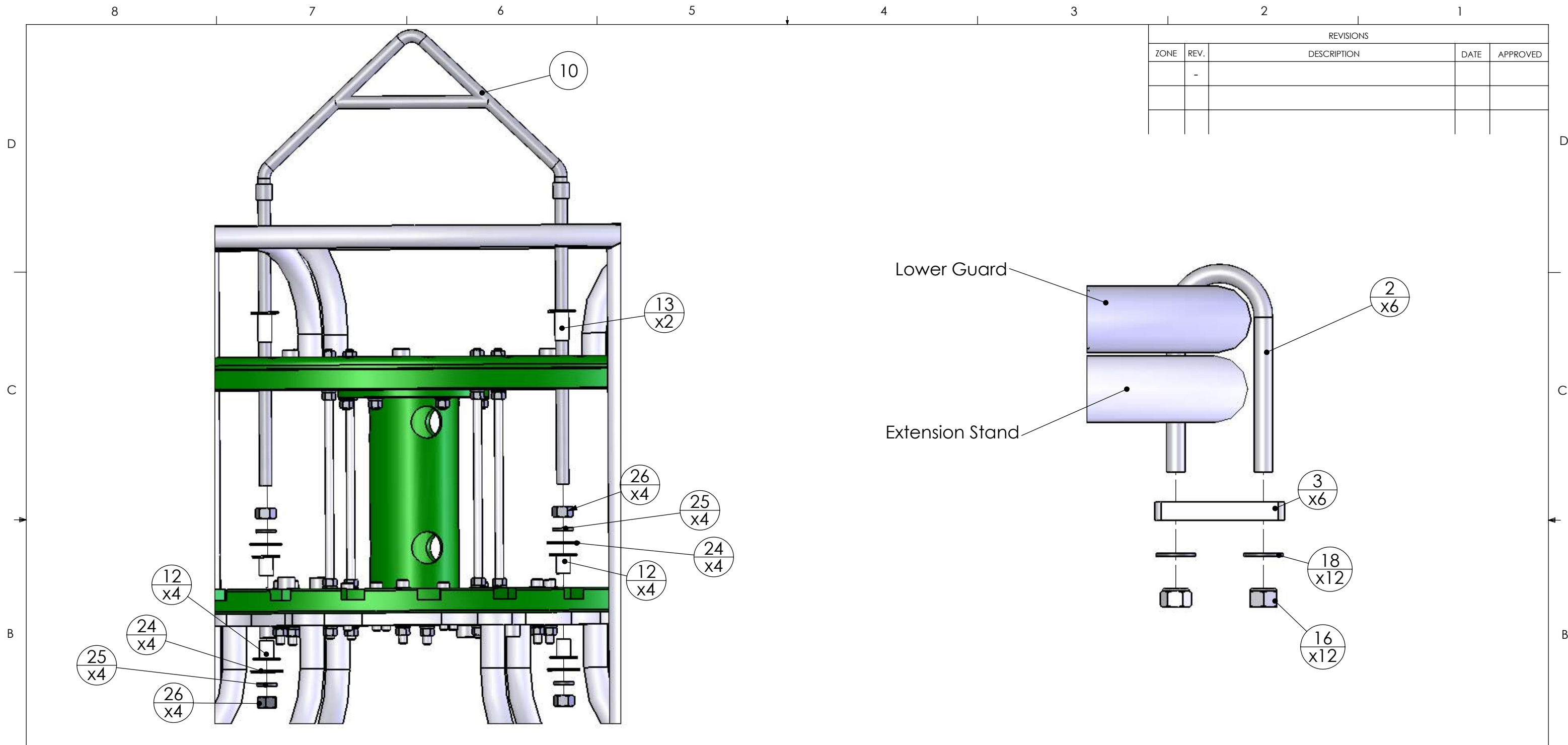

REVISIONS				
ZONE	REV.	DESCRIPTION	DATE	APPROVED
	-			

ITEM NO.	PN	DESCRIPTION	Default/QTY.
2	23714	SBE32 1.375"frame Cage U-bolt	6
3	23715	SBE32 1.375"frame Cage Flange	6
10	23723	SBE-32 LIFTING BALE 24LB	1
12	23922	SBE-32 LARGE BAIL INSULATOR	4
13	23923	SBE-32 LARGE BAIL INSULATOR	2
16	30210	Nut, 3/8-16 Nylon Stop	12
18	30257	WASHER, 3/8 FLAT, SS, 7/8" OD MAX	12
24	30615	WASHER, 3/4" FLAT, SS	4
25	30616	WASHER, 3/4" SPLIT RING LOCK, SS	4
26	30620	NUT, 3/4-10 NC HEX, SS	4

<small>UNLESS OTHERWISE SPECIFIED:          DIMENSIONS ARE IN INCHES          TOLERANCES:          FRACTIONAL ±          ANGULAR: ± 2 BEND ±          .XX ± .01 TYP RAD .015          .XXX ± .005          MACHINED SURFACES          INTERPRET GEOMETRIC          TOLERANCING PER:          ANSI Y14.5M - 1994</small>	NAME	DATE	<b>SEA-BIRD ELECTRONICS, INC.</b> 1808 - 136th PLACE NE, BELLEVUE, WA 98005 425-643-9866 TITLE: 1.375" frame, Universal Assembly P/N: none	
	DRAWN	klp		7/29/05
	<small>PROPRIETARY AND CONFIDENTIAL</small> THE INFORMATION CONTAINED IN THIS DRAWING IS THE SOLE PROPERTY OF SEA-BIRD ELECTRONICS, INC. ANY REPRODUCTION IN PART OR AS A WHOLE WITHOUT THE WRITTEN PERMISSION OF SEA-BIRD ELECTRONICS, INC. IS PROHIBITED.		COMMENTS:	SIZE DWG. NO. REV <b>B</b> 40713D
	MATERIAL #	Old Part/Draw Info N/A /N/A		SCALE: 1:2 SHEET 4 OF 4

HUB IS NOT INCLUDED:			HUB PART NUMBERS			HUB IS INCLUDED:		
6800M	7000M	10,500M	6800M	7000M	10,500M			
90409, 12-Position	90413, 12-Position	90416, 12-Position	90420, 12-Position	90425, 12-Position	90427, 12-Position			
90410, 24-Position	90414, 24-Position	90417, 24-Position	90421, 24-Position	90426, 24-Position	90428, 24-Position			
Subconn								
90476, 12-Position	90479, 12-Position	90482, 12-Position						
90477, 24-Position	90480, 24-Position	90483, 24-Position						

DATE	SYM	REVISION RECORD	AUTH.	DR.	CK.
07/28/94	A	P/Ns ADDED FOR 24/8,10,12	PG	DG	
08/23/94	B	P/Ns CHANGED FOR 12/1.7	RB	DG	
06/4/96	C	Updates for New Assemblies		JEB	
12.05.00	D	Update 12-20, Remove SC	CB	MJ	CB
12.04.02	E	See Rev.E Text File	CB	MJ	CB
12.03.03	F	Added Subconn to Pylon only	CB	KLP	CB
10.25.04	G	ADDED GUARD DIA. TABLE	MJ	KHH	
8.10.05	H	ADDED MORE KITS	KLP	KLP	

CAROUSEL ASSEMBLY PART NUMBERS

BOTTLE MOUNT STAND		△ ASSY DWG	FRAME SIZE	GUARD		GUARD SIDE BAR		CTD EXTENSION STAND		ADAPTER PLATES		LIFTING BAIL	CAGE U-BOLT	U-BOLT FLANGE	
DESCRIPTION	PRICE LIST P/N			UPPER	LOWER	1	2	SBE P/N	PRICE LIST P/N	TOP	BOTTOM				PRICE LIST P/N (SET)
12 BOTTLE / 1.2 LITER	80723	-none-	1 in.	23677C	-none-	23742C	23743C	23675C	80742	70071 (SET)		80737	23678	23694	23695
12 BOTTLE / 1.7 LITER	80723	41468	1 in.	23677C	23676C	23679C	23681C	23675C	80742	70071 (SET)		80737	23678	23694	23695
12 BOTTLE / 2.5 LITER	80724	41466	1 in.	23677C	23741C	23739C	23740C	23675C	80742	70071 (SET)		80737	23678	23694	23695
12 BOTTLE / 5 LITER	80725	41468	1 in.	23677C	23676C	23679C	23681C	23675C	80742	70071 (SET)		80738	23678	23694	23695
12 BOTTLE / 8 LITER	80726	41466	1 in.	23677C	23741C	23739C	23740C	23675C	80742	70071 (SET)		80738	23678	23694	23695
12 BOTTLE / 10 LITER	80727	41469	1 in.	23677C	23683C	23680C	23682C	23675C	80742	70071 (SET)		80738	23678	23694	23695
12 BOTTLE / 12 LITER	80728	41470	1 in.	23677C	23703C	23701C	23702C	23675C	80742	70071 (SET)		80738	23678	23694	23695
12 BOTTLE / 20 LITER	80729	41438	1.375 in.	23720C	23857C	23855C	23856C	23724C	80743	23902C	23903C	80739	23723	23714	23715
12 BOTTLE / 30 LITER	80730	41439	1.375 in.	23720C	23783C	23781C	23782C	23724C	80743	23902C	23903C	80739	23723	23714	23715
24 BOTTLE / 1.2 LITER	80731	-none-	1 in.	23736C	-none-	23742C	23743C	23738C	80744	23729C	23730C	80740	23678	23694	23695
24 BOTTLE / 1.7 LITER	80731	-none-	1 in.	23736C	-none-	23742C	23743C	23738C	80744	23729C	23730C	80740	23678	23694	23695
24 BOTTLE / 2.5 LITER	80732	41467	1 in.	23736C	23737C	23725C	23726C	23738C	80744	23729C	23730C	80740	23678	23694	23695
24 BOTTLE / 5 LITER	80733	41434	1.375 in.	23720C	23719C	23721C	23722C	23724C	80743	23716C	23717C	80741	23723	23714	23715
24 BOTTLE / 8 LITER	80734	41435	1.375 in.	23720C	23857C	23855C	23856C	23724C	80743	23716C	23717C	80741	23723	23714	23715
24 BOTTLE / 10 LITER	80735	41436	1.375 in.	23720C	23854C	23852C	23853C	23724C	80743	23716C	23717C	80741	23723	23714	23715
24 BOTTLE / 12 LITER	80736	41437	1.375 in.	23720C	23783C	23781C	23782C	23724C	80743	23716C	23717C	80741	23723	23714	23715

NOTES:

- REFER TO FRAME ASSEMBLY DRAWING 40713 FOR PART LOCATIONS.
- ASSEMBLY DRAWING DOES NOT INCLUDE BOTTLES, PYLON & SENSORS

TOLERANCES	SEA-BIRD ELECTRONICS, INC				
FRACTIONAL	P/N	SCALE	DRAWN BY DG		
		-	APPROVED BY		
DECIMAL	TITLE				
	SBE 32 CAROUSEL : FRAME COMPONENTS				
ANGULAR	DATE	DWG NO.	SHEET 1 OF 2		REV
	4/11/94	40714			H

DATE	SYM	REVISION RECORD	AUTH.	DR.	CK.
07/28/94	A	P/Ns ADDED FOR 24/8,10,12	PG	DG	
08/23/94	B	P/Ns CHANGED FOR 12/1.7	RB	DG	
06/4/96	C	Updates for New Assemblies		JEB	
12.05.00	D	Update 12-20, Remove SC	CB	MJ	CB
12.04.02	E	See Rev.E Text File	CB	MJ	CB
12.03.03	F	Added Subconn to Pylon only	CB	KLP	CB
10.25.04	G	ADDED GUARD DIA. TABLE	MJ	KHH	
8.10.05	H	ADDED MORE KITS	KLP	KLP	

ASSEMBLY KITS



BOTTLE MOUNT STAND	FRAME SIZE	HARDWARE	LIFT BAIL	EXTENSION STAND CTD INSTALL	DECK PAD	U-Bolt Sets	
12 BOTTLE / 1.2 LITER	1 in.	50112	50111	50199	50297	50211	
12 BOTTLE / 1.7 LITER	1 in.	50112	50111	50199	50297	50211	
12 BOTTLE / 2.5 LITER	1 in.	50112	50111	50199	50297	50211	
12 BOTTLE / 5 LITER	1 in.	50112	50111	50199	50297	50211	
12 BOTTLE / 8 LITER	1 in.	50112	50111	50199	50297	50211	
12 BOTTLE / 10 LITER	1 in.	50112	50111	50199	50297	50211	
12 BOTTLE / 12 LITER	1 in.	50112	50111	50199	50297	50211	
12 BOTTLE / 20 LITER	1.375 in.	50115	50156	50199	50296	50212	
12 BOTTLE / 30 LITER	1.375 in.	50115	50156	50199	50296	50212	
24 BOTTLE / 1.2 LITER	1 in.	50112	50111	50199	50297	50211	
24 BOTTLE / 1.7 LITER	1 in.	50112	50111	50199	50297	50211	
24 BOTTLE / 2.5 LITER	1 in.	50112	50111	50199	50297	50211	
24 BOTTLE / 5 LITER	1.375 in.	50115	50156	50199	50296	50212	
24 BOTTLE / 8 LITER	1.375 in.	50115	50156	50199	50296	50212	
24 BOTTLE / 10 LITER	1.375 in.	50115	50156	50199	50296	50212	
24 BOTTLE / 12 LITER	1.375 in.	50115	50156	50199	50296	50212	

1. REFER TO FRAME ASSEMBLY DRAWING 40713 FOR PART LOCATIONS.
2. ASSEMBLY DRAWING DOES NOT INCLUDE BOTTLES, PYLON & SENSORS

TOLERANCES	SEA-BIRD ELECTRONICS, INC			
FRACTIONAL	P/N	SCALE	DRAWN BY DG	
		-	APPROVED BY	
DECIMAL	TITLE			
	SBE 32 CAROUSEL : FRAME COMPONENTS			
ANGULAR	DATE	DWG NO.	REV	
	4/11/94	SHEET 2 OF 2 40714	H	

DATE	SYM	REVISION RECORD	AUTH.	DR.	CK.

- 1/2 FLAT WASHER #30259, 24 EACH
- 1/2 LOCK WASHER #30594, 12 EACH
- 1/2-13 HEX NUT #30231, 12 EACH
- 1/2-13 X 2-1/2 SOCKET HEAD CAP SCREW, SS #30612, 12 EACH

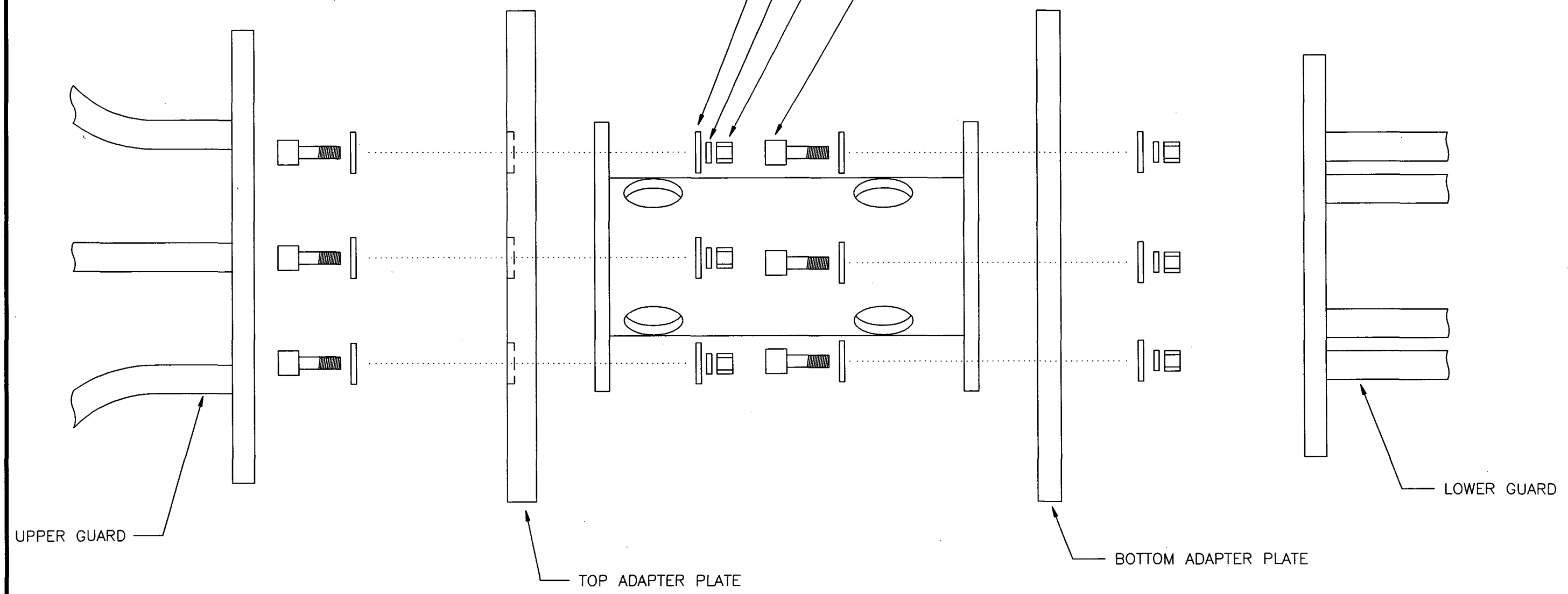

TOLERANCES	SEA-BIRD ELECTRONICS, INC			
FRACTIONAL	P/N	SCALE	DRAWN BY CEG	
DECIMAL	TITLE SBE 32 HUB/ADAPTER PLATE ASSEMBLY DETAIL (24 PLACE)		APPROVED BY	
ANGULAR	DATE 2.2.98	DRAWING NUMBER 40943	REV	

8 7 6 5 4 3 2 1

REVISIONS				
ZONE	REV.	DESCRIPTION	DATE	APPROVED
	-			

D

D

C

C

B

B

A

A

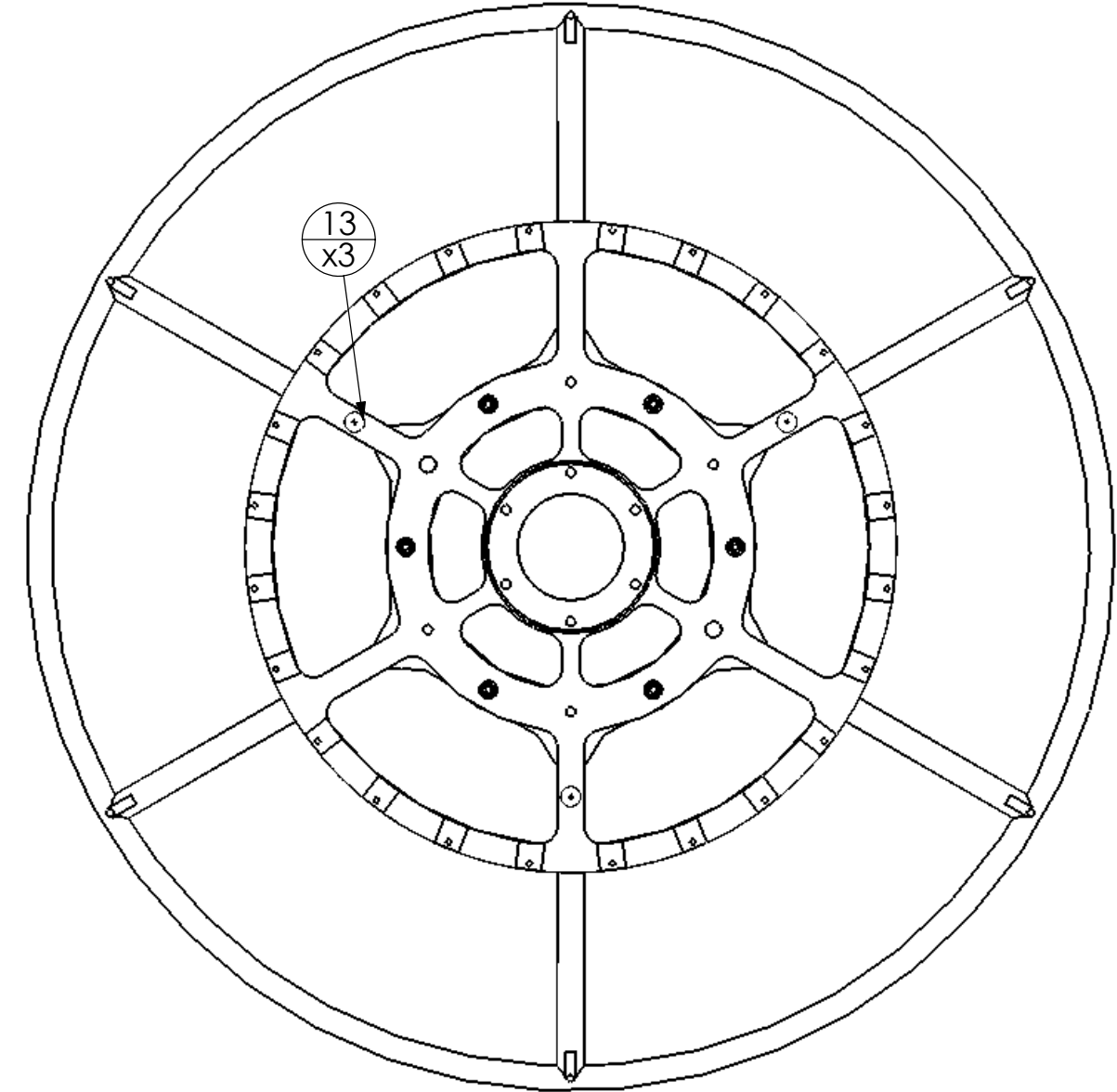
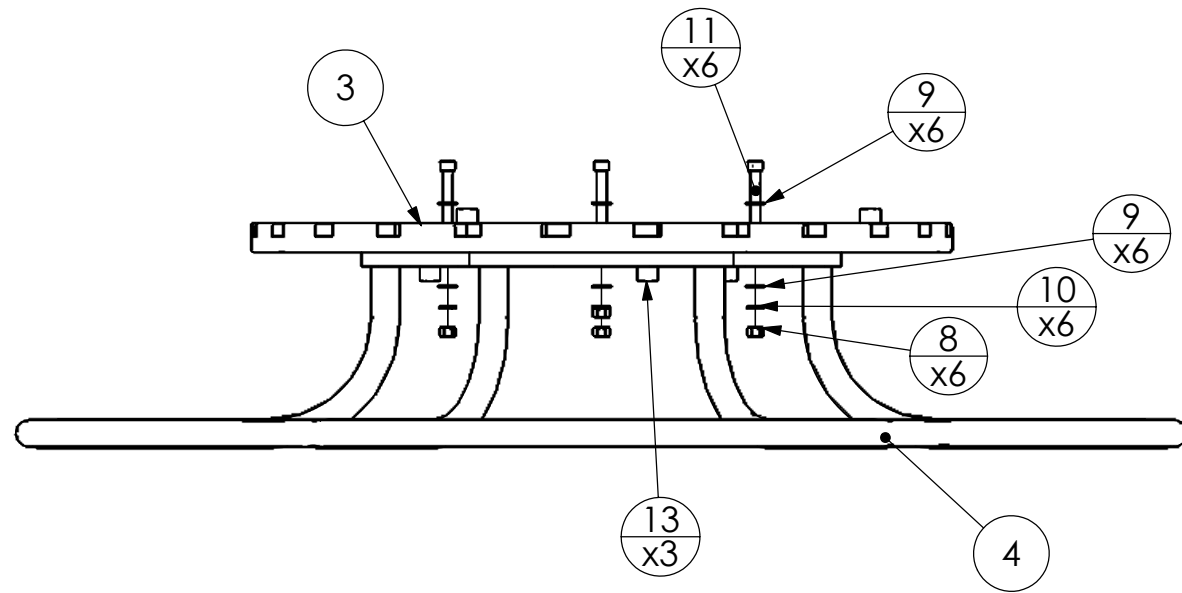

ITEM NO.	PART NUMBER	DESCRIPTION	bottom plate/QTY.
3	23717	SB3-32 BOTTOM ADAPTER PLATE	1
4	23719	SBE32 CAROUSEL 24 PLACE 5 LITER LOWER GUARD	1
8	30231	NUT, 1/2-13 HEX, SS	6
9	30259	WASHER, 1/2" FLAT/NARROW, AN960C816L, SS	12
10	30594	WASHER, 1/2" SPLIT RING LOCK, SS	6
11	30603	CAP SCREW, 1/2-13 X 3-1/2" SOCKET HEAD, SS	6
13	30044	SEACAT ANODE, 1" DIA., G1050	6

UNLESS OTHERWISE SPECIFIED: DIMENSIONS ARE IN INCHES TOLERANCES: FRACTIONAL ± ANGULAR: ±2 BEND ± .XX ±.01 TYP RAD .015 .XXX ±.005 MACHINED SURFACES INTERPRET GEOMETRIC TOLERANCING PER: ANSI Y14.5M - 1994		NAME <b>klp</b>	DATE <b>7/29/05</b>	<b>SEA-BIRD ELECTRONICS, INC.</b> 1808 - 136th PLACE NE, BELLEVUE, WA 98005 425-643-9866 TITLE: 1.375" frame, 24place, 5 Liter P/N: <b>none</b>
MATERIAL #		PROPRIETARY AND CONFIDENTIAL THE INFORMATION CONTAINED IN THIS DRAWING IS THE SOLE PROPERTY OF SEA-BIRD ELECTRONICS, INC. ANY REPRODUCTION IN PART OR AS A WHOLE WITHOUT THE WRITTEN PERMISSION OF SEA-BIRD ELECTRONICS, INC. IS PROHIBITED. COMMENTS: <b>DEBUR AND BREAK SHARP EDGES</b> Old Part/Draw Info N/A /N/A		
FINISH N/A		DWG. NO. <b>41434</b>		REV
DO NOT SCALE DRAWING		SCALE: 1:2		SHEET 1 OF 6

8 7 6 5 4 3 2 1

8 7 6 5 4 3 2 1

REVISIONS				
ZONE	REV.	DESCRIPTION	DATE	APPROVED
	-			

D

D

C

C

B

B

A

A

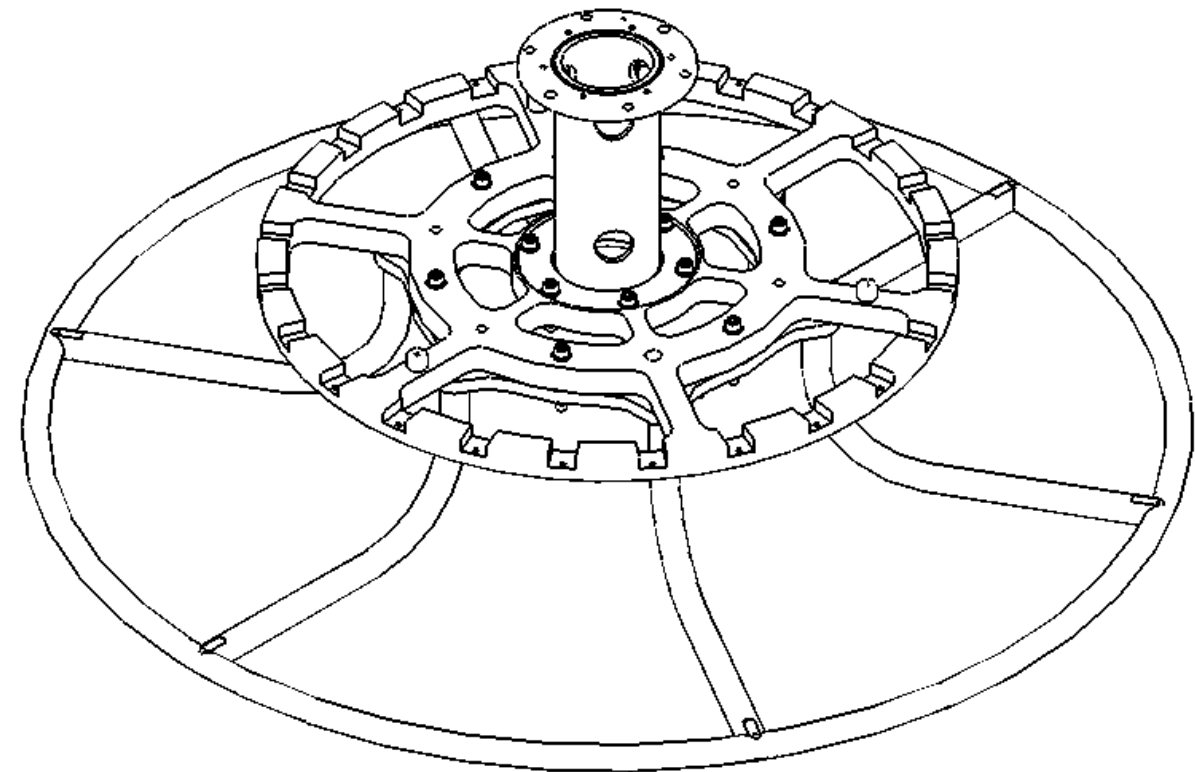
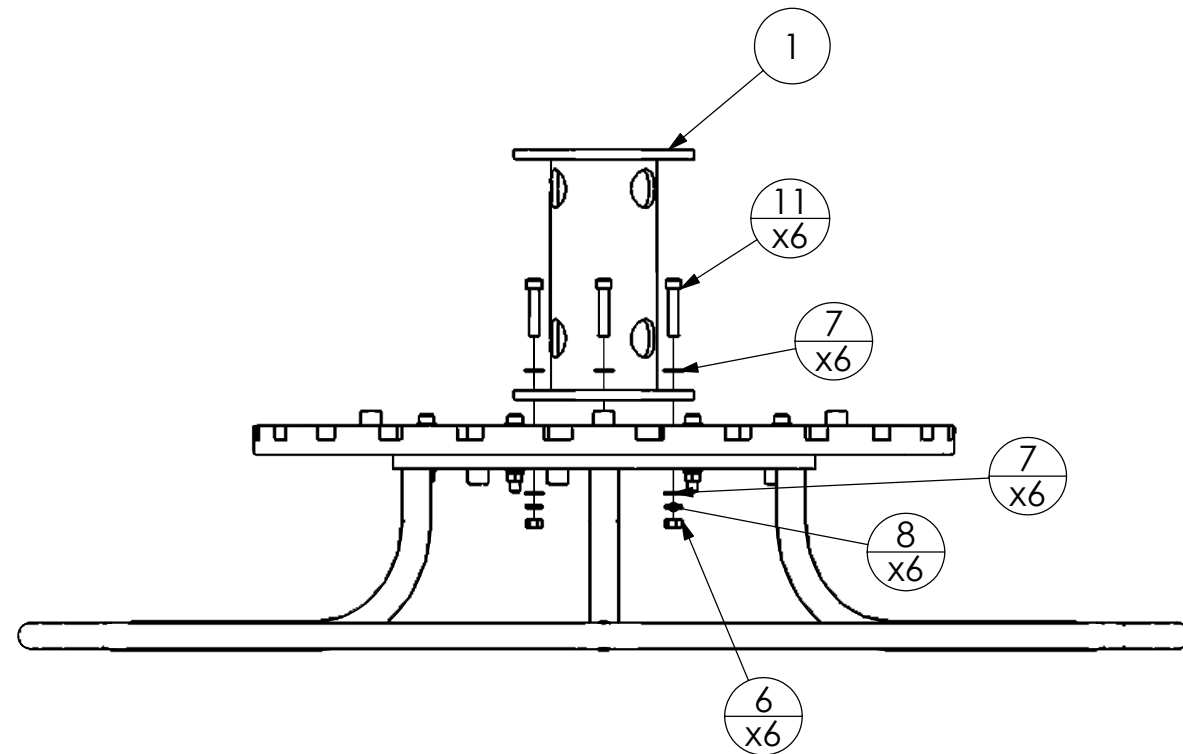

ITEM NO.	PART NUMBER	DESCRIPTION	hub/QTY.
1	23668	SBE32 HUB	1
6	30231	NUT, 1/2-13 HEX, SS	12
7	30259	WASHER, 1/2" FLAT/NARROW, AN960C816L, SS	24
8	30594	WASHER, 1/2" SPLIT RING LOCK, SS	12
11	30612	CAP SCREW, 1/2-13 X 2-1/2" SOCKET HEAD, SS	6

UNLESS OTHERWISE SPECIFIED:		NAME	DATE	SEA-BIRD ELECTRONICS, INC. 1808 - 136th PLACE NE, BELLEVUE, WA 98005 425-643-9866
DIMENSIONS ARE IN INCHES		klp	7/29/05	
TOLERANCES:		PROPRIETARY AND CONFIDENTIAL		
FRACTIONAL ±		THE INFORMATION CONTAINED IN THIS DRAWING IS THE SOLE PROPERTY OF SEA-BIRD ELECTRONICS, INC. ANY REPRODUCTION IN PART OR AS A WHOLE WITHOUT THE WRITTEN PERMISSION OF SEA-BIRD ELECTRONICS, INC. IS PROHIBITED.		
ANGULAR: ±2 BEND ±		COMMENTS:		
.XX ±.01 TYP RAD .015		DEBUR AND BREAK SHARP EDGES		
.XXX ±.005		Old Part/Draw Info		
MACHINED SURFACES		N/A /N/A		
INTERPRET GEOMETRIC TOLERANCING PER: ANSI Y14.5M - 1994		SCALE: 1:2		
MATERIAL #		DWG. NO.		REV
FINISH N/A		B 41434		
DO NOT SCALE DRAWING		SHEET 2 OF 6		

8 7 6 5 4 3 2 1

REVISIONS				
ZONE	REV.	DESCRIPTION	DATE	APPROVED

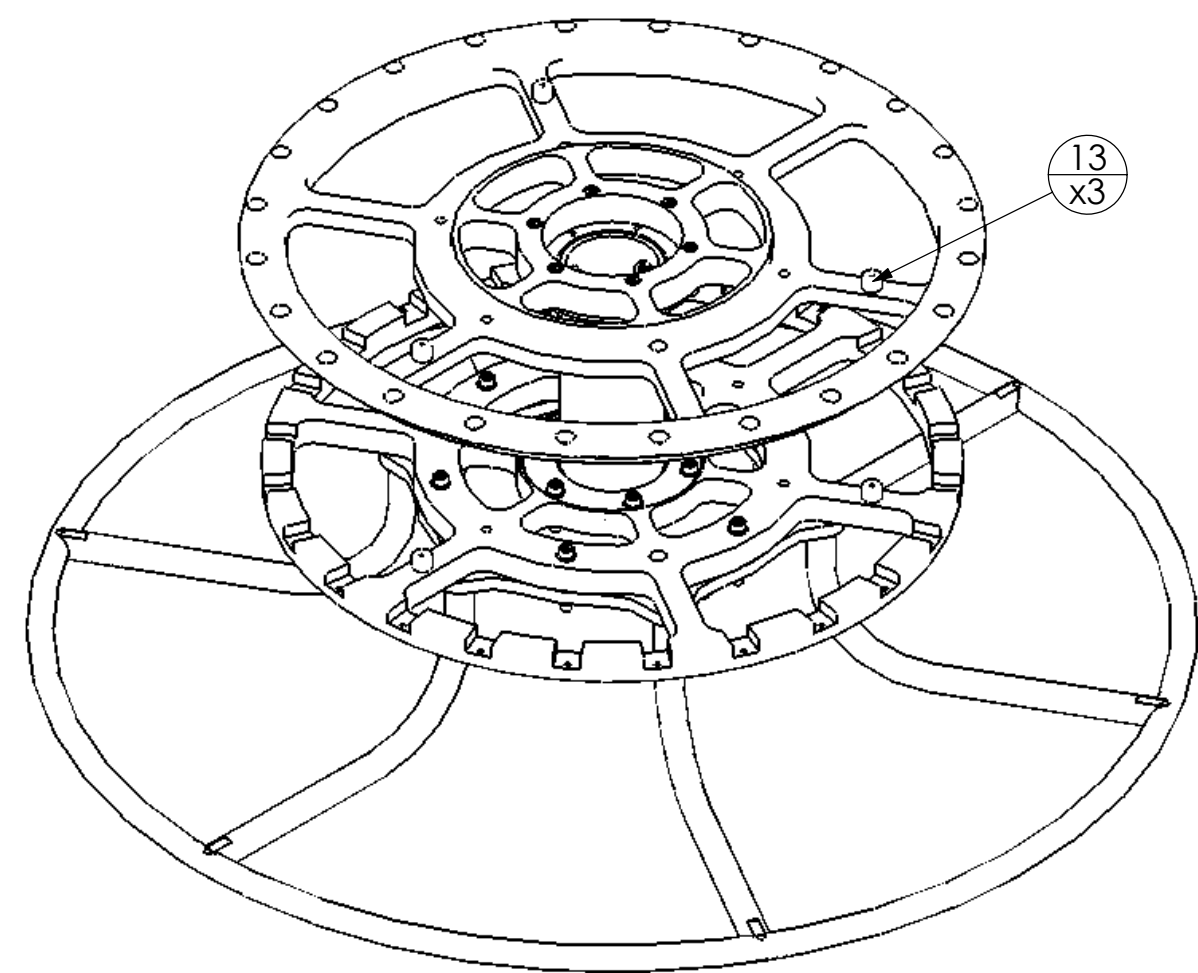
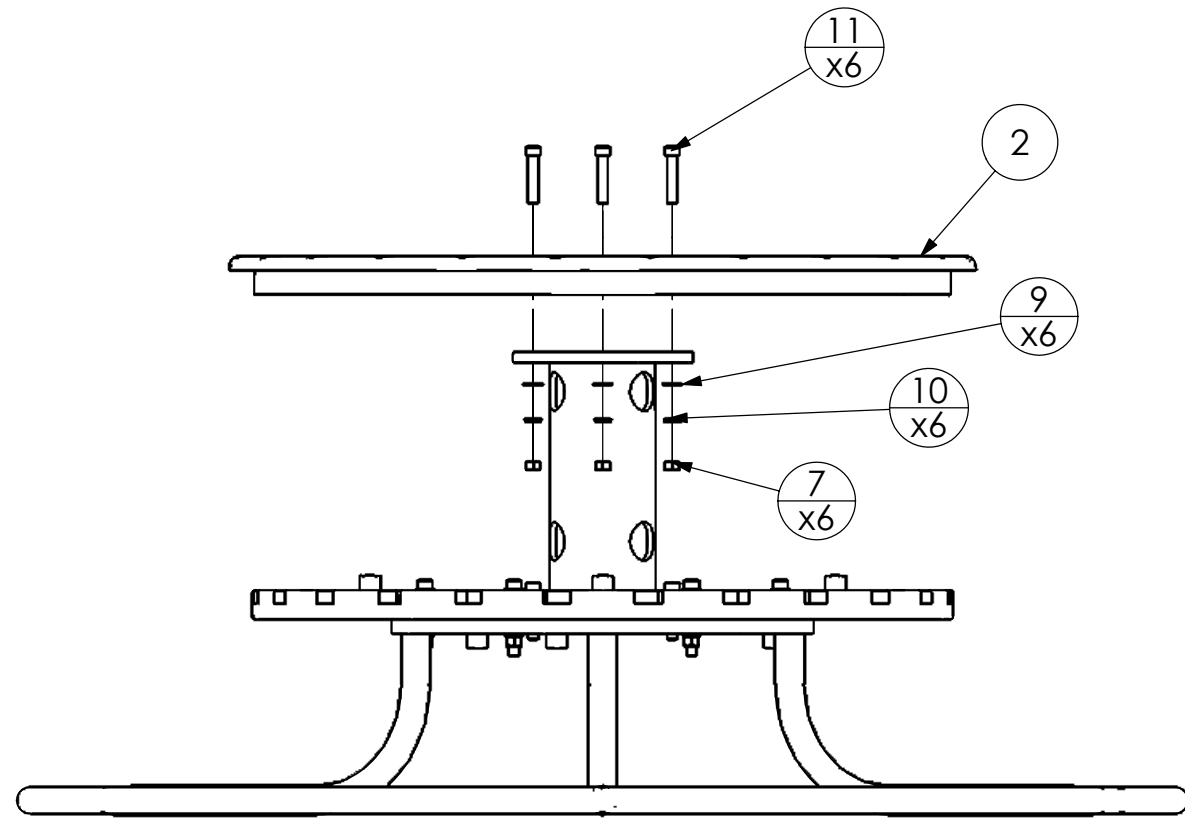

ITEM NO.	PART NUMBER	DESCRIPTION	top plate/QT Y.
2	23716	SBE-32 TOP ADAPTER PLATE	1
7	30231	NUT, 1/2-13 HEX, SS	18
9	30259	WASHER, 1/2" FLAT/NARROW, AN960C816L, SS	30
10	30594	WASHER, 1/2" SPLIT RING LOCK, SS	18
11	30612	CAP SCREW, 1/2-13 X 2-1/2" SOCKET HEAD, SS	12
13	30044	SEACAT ANODE, 1" DIA., G1050	9

<small>UNLESS OTHERWISE SPECIFIED:  DIMENSIONS ARE IN INCHES  TOLERANCES:  FRACTIONAL ±  ANGULAR: ± 2 BEND ±  .XX ± .01 TYP RAD .015  .XXX ± .005  MACHINED SURFACES  INTERPRET GEOMETRIC  TOLERANCING PER:  ANSI Y14.5M - 1994</small>	NAME	DATE	<b>SEA-BIRD ELECTRONICS, INC.</b> 1808 - 136th PLACE NE, BELLEVUE, WA 98005 425-643-9866 TITLE: 1.375" frame, 24place, 5 Liter P/N: none	
	DRAWN	klp		7/29/05
	<small>PROPRIETARY AND CONFIDENTIAL</small> THE INFORMATION CONTAINED IN THIS DRAWING IS THE SOLE PROPERTY OF SEA-BIRD ELECTRONICS, INC. ANY REPRODUCTION IN PART OR AS A WHOLE WITHOUT THE WRITTEN PERMISSION OF SEA-BIRD ELECTRONICS, INC. IS PROHIBITED.		COMMENTS:	SIZE DWG. NO. REV <b>B</b> 41434
	MATERIAL #	DEBUR AND BREAK SHARP EDGES Old Part/Draw Info N/A /N/A		SCALE: 1:2 SHEET 3 OF 6
FINISH	N/A			
DO NOT SCALE DRAWING				



REVISIONS				
ZONE	REV.	DESCRIPTION	DATE	APPROVED
	-			

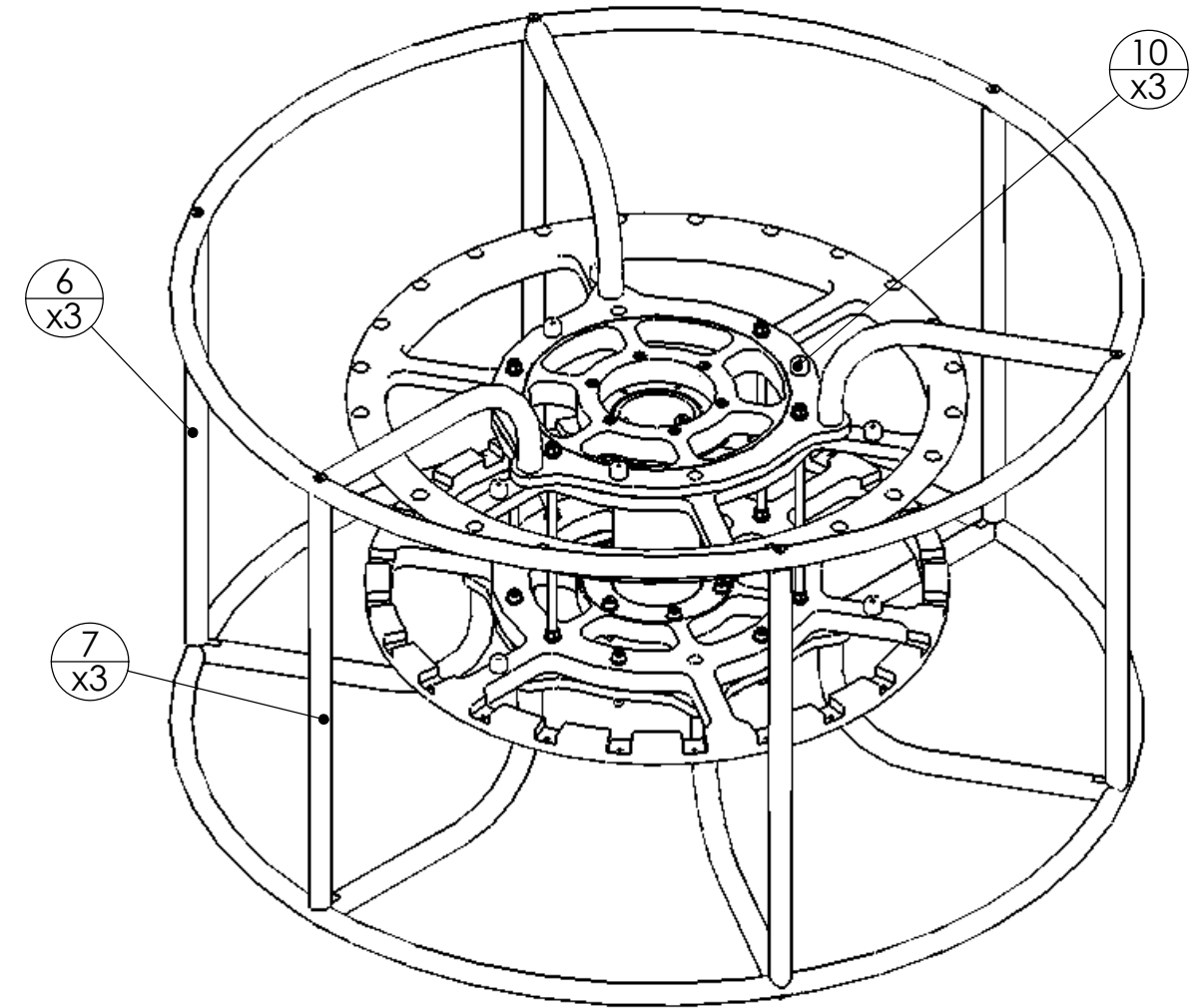
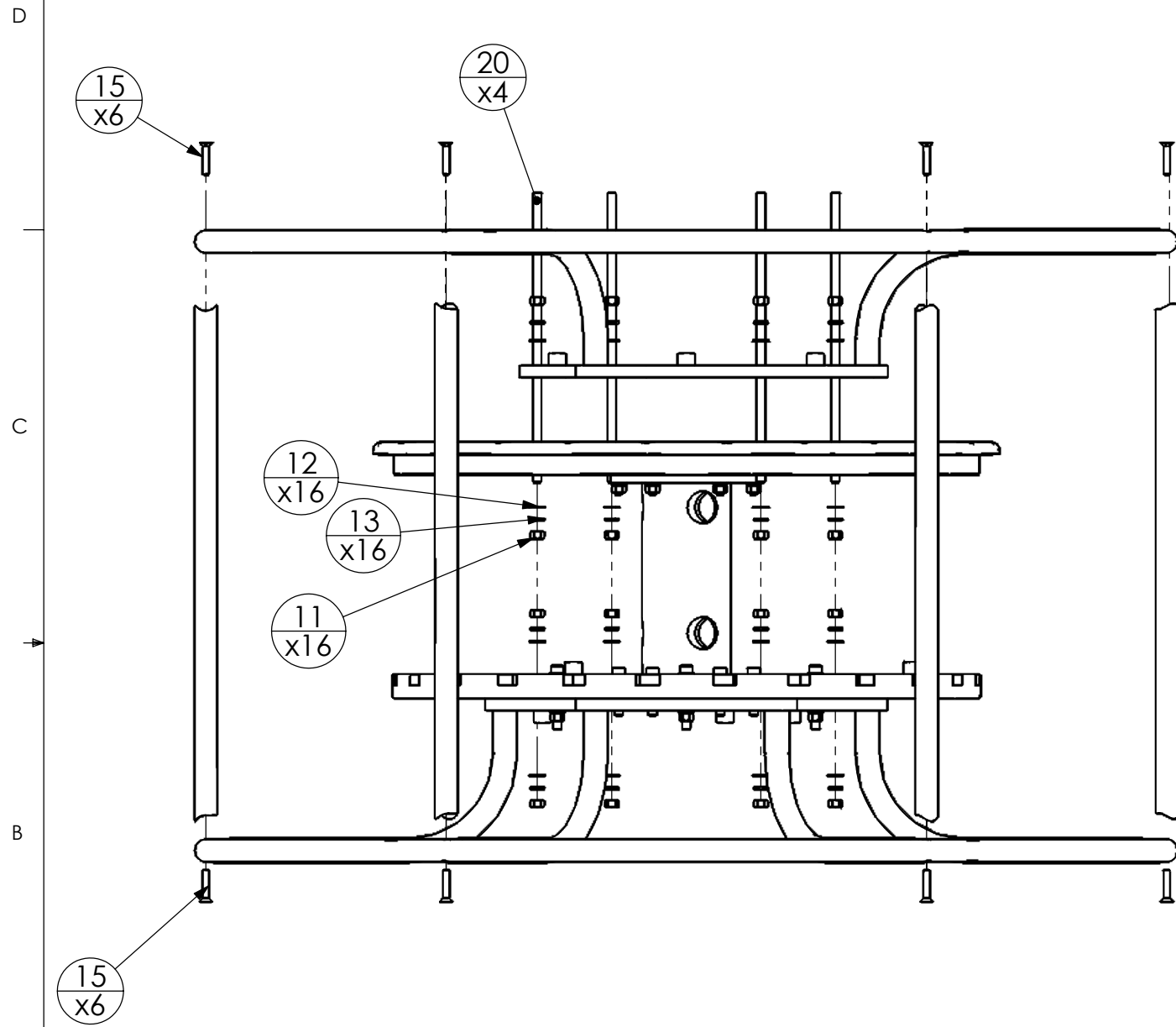

ITEM NO.	PART NUMBER	DESCRIPTION	top guard/QTY.
6	23721	SBE-32 CAROUSEL 24 PLACE 5-12 LITER GUARD SIDE BAR 1	3
7	23722	SBE-32 CAROUSEL 24 PLACE 5-12 LITER GUARD SIDE BAR 2	3
10	30044	SEACAT ANODE, 1" DIA., G1050	12
11	30231	NUT, 1/2-13 HEX, SS	34
12	30259	WASHER, 1/2" FLAT/NARROW, AN960C816L, SS	46
13	30594	WASHER, 1/2" SPLIT RING LOCK, SS	34
15	30611	3/8-16 X 2" FLAT HEAD SOCKET, SS	12
20	231421	ROD, 1/2-13 THREADED 18" LENGTH, SS	4

UNLESS OTHERWISE SPECIFIED: DIMENSIONS ARE IN INCHES TOLERANCES: FRACTIONAL ± ANGULAR: ±2 BEND ± .XX ±.01 TYP RAD .015 .XXX ±.005 MACHINED SURFACES INTERPRET GEOMETRIC TOLERANCING PER: ANSI Y14.5M - 1994		NAME klp	DATE 7/29/05	SEA-BIRD ELECTRONICS, INC. 1808 - 136th PLACE NE, BELLEVUE, WA 98005 425-643-9866 TITLE: 1.375" frame, 24place, 5 Liter P/N: none
MATERIAL #		PROPRIETARY AND CONFIDENTIAL THE INFORMATION CONTAINED IN THIS DRAWING IS THE SOLE PROPERTY OF SEA-BIRD ELECTRONICS, INC. ANY REPRODUCTION IN PART OR AS A WHOLE WITHOUT THE WRITTEN PERMISSION OF SEA-BIRD ELECTRONICS, INC. IS PROHIBITED.		
FINISH N/A	COMMENTS: DEBUR AND BREAK SHARP EDGES	Old Part/Draw Info N/A /N/A	SIZE <b>B</b>	DWG. NO. <b>41434</b>
DO NOT SCALE DRAWING		SCALE: 1:2		SHEET 4 OF 6

REVISIONS				
ZONE	REV.	DESCRIPTION	DATE	APPROVED
	-			

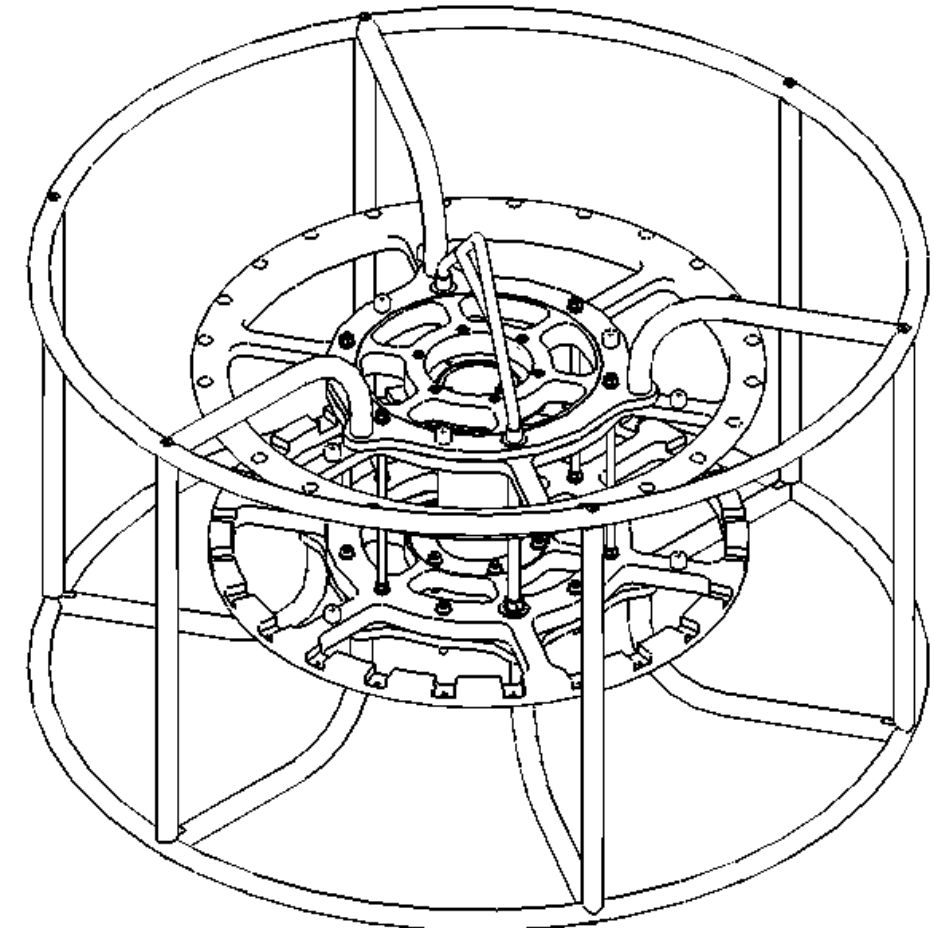
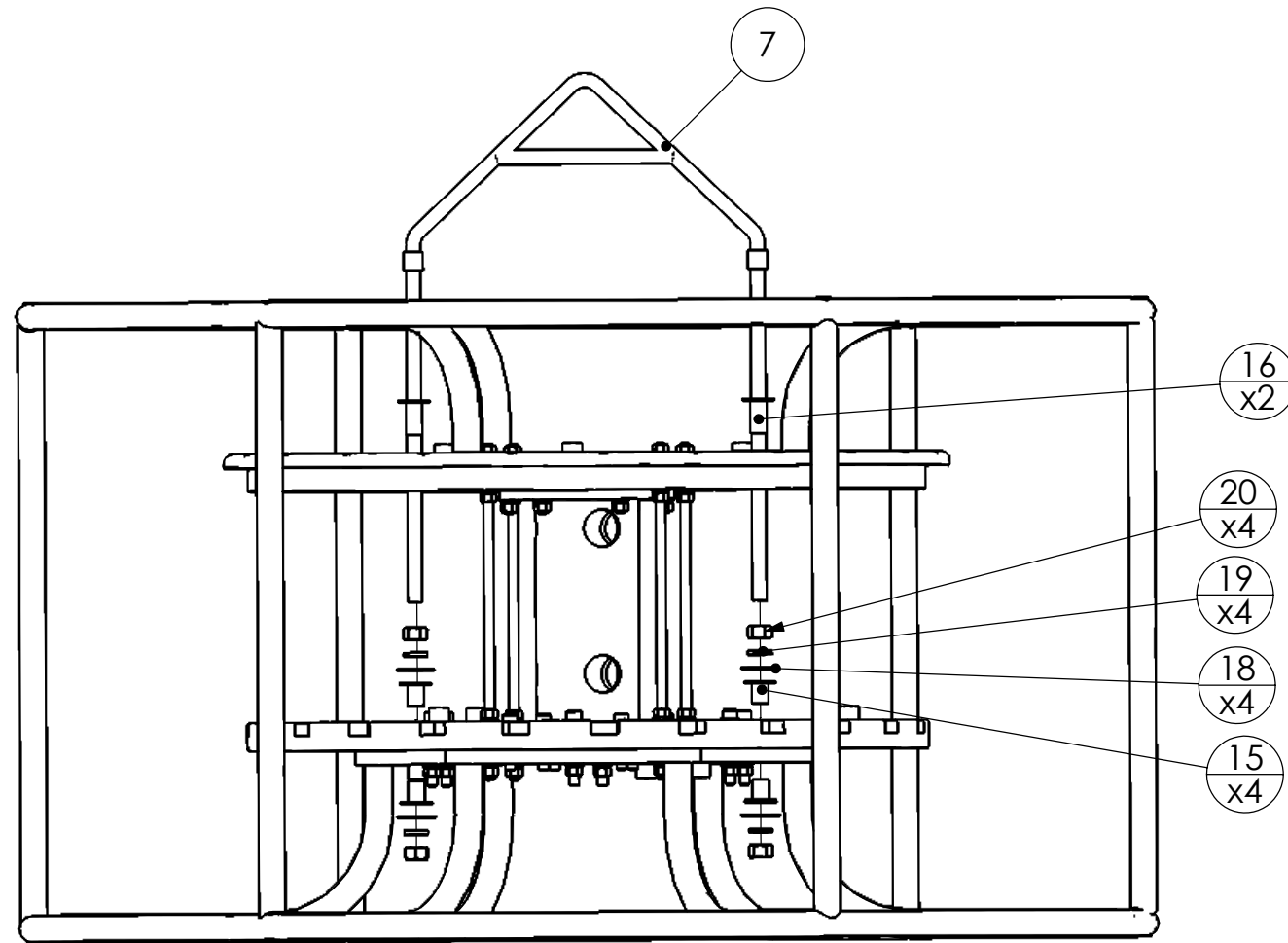

ITEM NO.	PART NUMBER	DESCRIPTION	lifting bale/QTY
7	23723	SBE-32 LIFTING BALE 24LB	1
15	23922	SBE-32 LARGE BAIL INSULATOR	4
16	23923	SBE-32 LARGE BAIL INSULATOR	2
18	30615	WASHER, 3/4" FLAT, SS	4
19	30616	WASHER, 3/4" SPLIT RING LOCK, SS	4
20	30620	NUT, 3/4-10 NC HEX, SS	4

UNLESS OTHERWISE SPECIFIED: DIMENSIONS ARE IN INCHES TOLERANCES: FRACTIONAL ± ANGULAR: ±2 BEND ± .XX ±.01 TYP RAD .015 .XXX ±.005 MACHINED SURFACES INTERPRET GEOMETRIC TOLERANCING PER: ANSI Y14.5M - 1994		NAME klp	DATE 7/29/05	SEA-BIRD ELECTRONICS, INC. 1808 - 136th PLACE NE, BELLEVUE, WA 98005 425-643-9866 TITLE: 1.375" frame, 24place, 5 Liter P/N: none
MATERIAL #		PROPRIETARY AND CONFIDENTIAL THE INFORMATION CONTAINED IN THIS DRAWING IS THE SOLE PROPERTY OF SEA-BIRD ELECTRONICS, INC. ANY REPRODUCTION IN PART OR AS A WHOLE WITHOUT THE WRITTEN PERMISSION OF SEA-BIRD ELECTRONICS, INC. IS PROHIBITED.		
FINISH N/A		COMMENTS: DEBUR AND BREAK SHARP EDGES Old Part/Draw Info		SIZE B
DO NOT SCALE DRAWING		N/A /N/A		DWG. NO. 41434 REV
			SCALE: 1:2	SHEET 5 OF 6

8 7 6 5 4 3 2 1

REVISIONS				
ZONE	REV.	DESCRIPTION	DATE	APPROVED
	-			

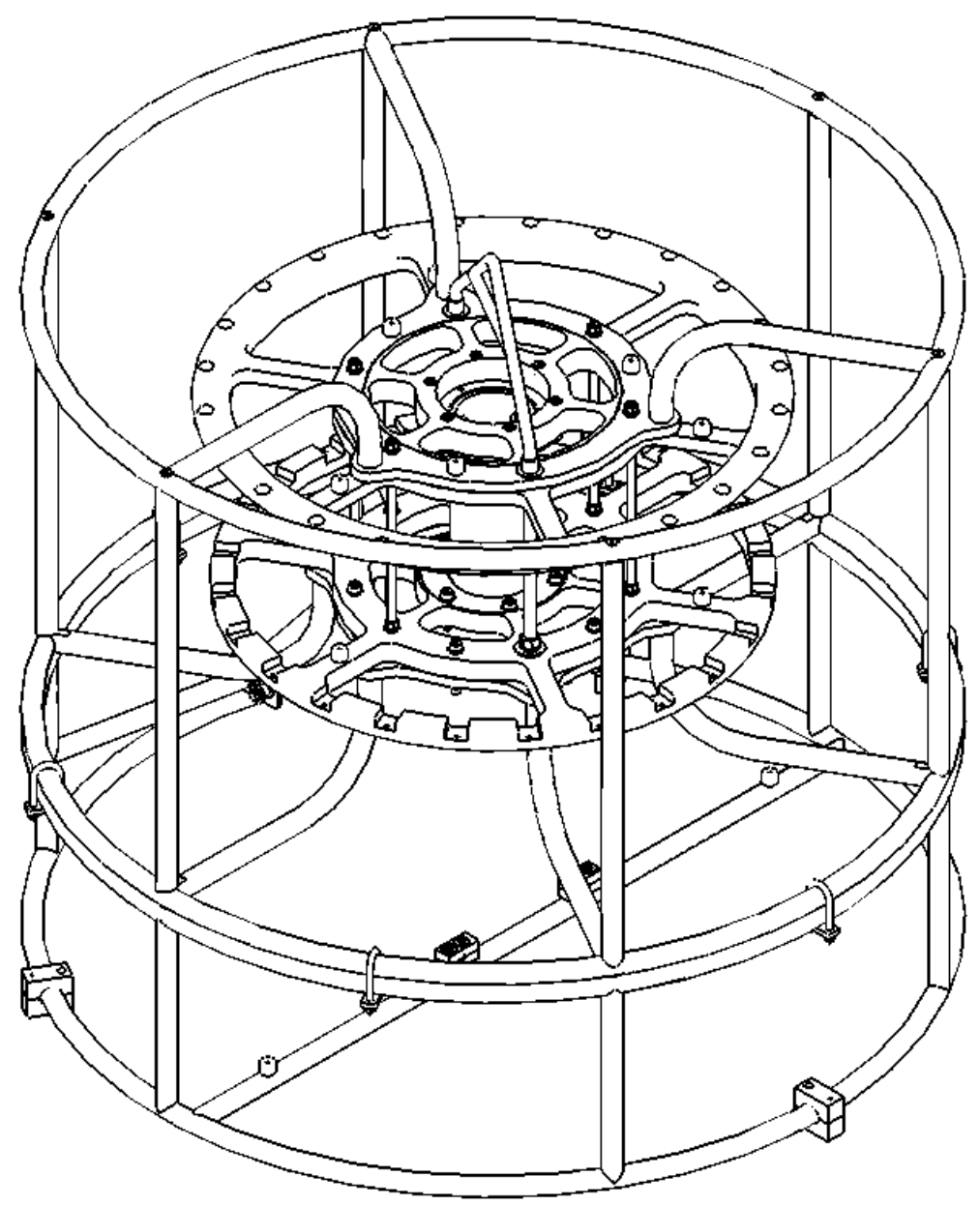
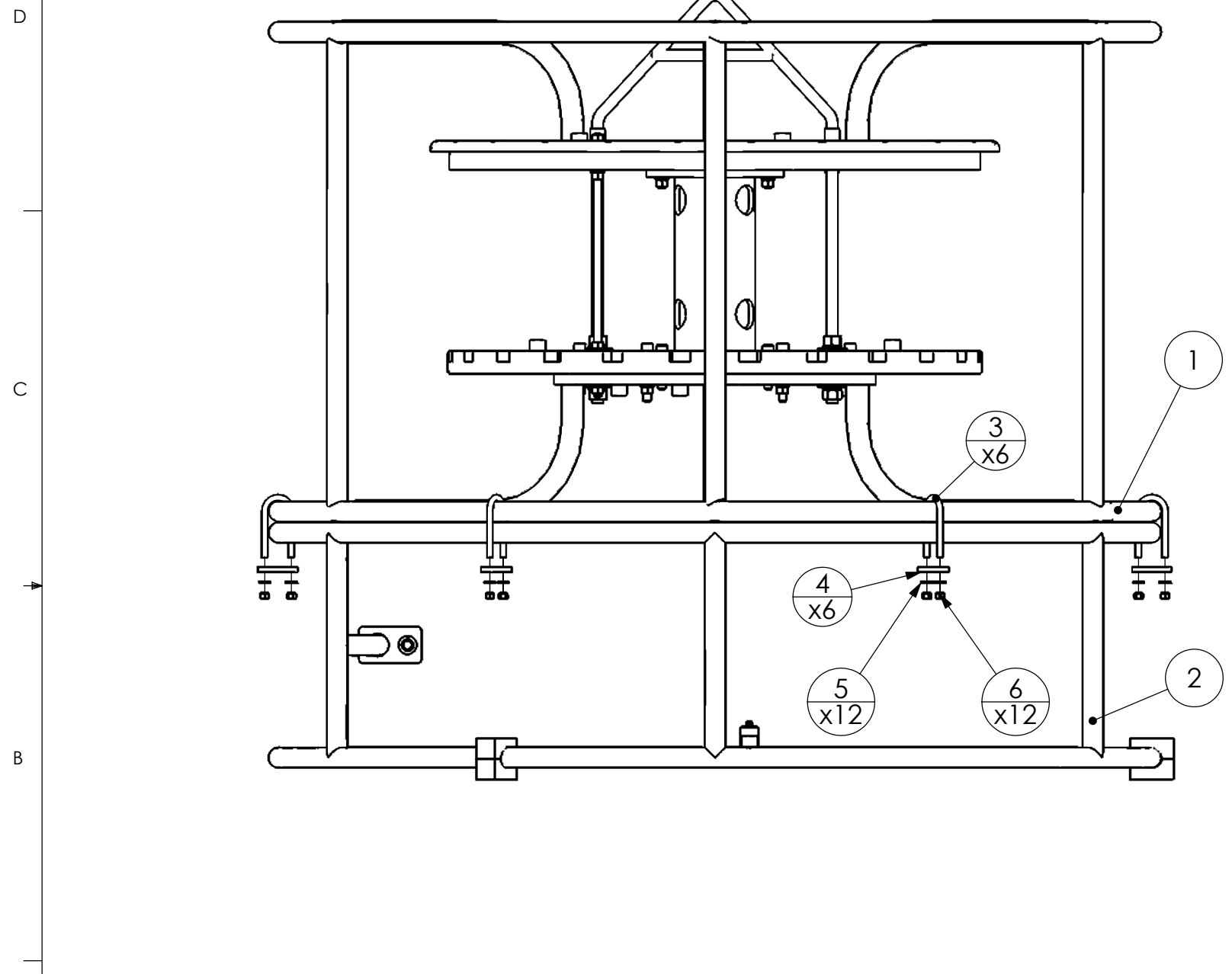

ITEM NO.	PART NUMBER	DESCRIPTION	extension frame/QTY.
1	23719	SBE32 CAROUSEL 24 PLACE 5 LITER LOWER GUARD	1
2	23724	SBE-32 CAROUSEL 24 PLACE 5-12 LITER EXTENSION STAND	1
3	23714	SBE32 1.375"frame Cage U-bolt	6
4	23715	SBE32 1.375"frame Cage Flange	6
5	30257	WASHER, 3/8 FLAT, SS, 7/8" OD MAX	12
6	30210	Nut, 3/8-16 Nylon Stop	12

UNLESS OTHERWISE SPECIFIED: DIMENSIONS ARE IN INCHES TOLERANCES: FRACTIONAL ± ANGULAR: ± 2 BEND ± .XX ± .01 TYP RAD .015 .XXX ± .005 MACHINED SURFACES INTERPRET GEOMETRIC TOLERANCING PER: ANSI Y14.5M - 1994		NAME klp	DATE 7/29/05	SEA-BIRD ELECTRONICS, INC. 1808 - 136th PLACE NE, BELLEVUE, WA 98005 425-643-9866 TITLE: 1.375" frame, 24place, 5 Liter P/N: none
DRAWN		PROPRIETARY AND CONFIDENTIAL THE INFORMATION CONTAINED IN THIS DRAWING IS THE SOLE PROPERTY OF SEA-BIRD ELECTRONICS, INC. ANY REPRODUCTION IN PART OR AS A WHOLE WITHOUT THE WRITTEN PERMISSION OF SEA-BIRD ELECTRONICS, INC. IS PROHIBITED.		
MATERIAL #	FINISH N/A	COMMENTS: DEBUR AND BREAK SHARP EDGES Old Part/Draw Info N/A /N/A		SIZE B
DO NOT SCALE DRAWING		SCALE: 1:2		DWG. NO. 41434
				REV SHEET 6 OF 6

8 7 6 5 4 3 2 1