

DATE	SYM	REVISION RECORD	AUTH.	DR.	CK.
4/91	A	REDRAWN SEE HISTORY	KL	BMc	
3/93	B	ADDED COLOR 1	KL	BMc	

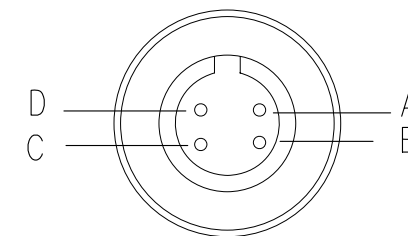
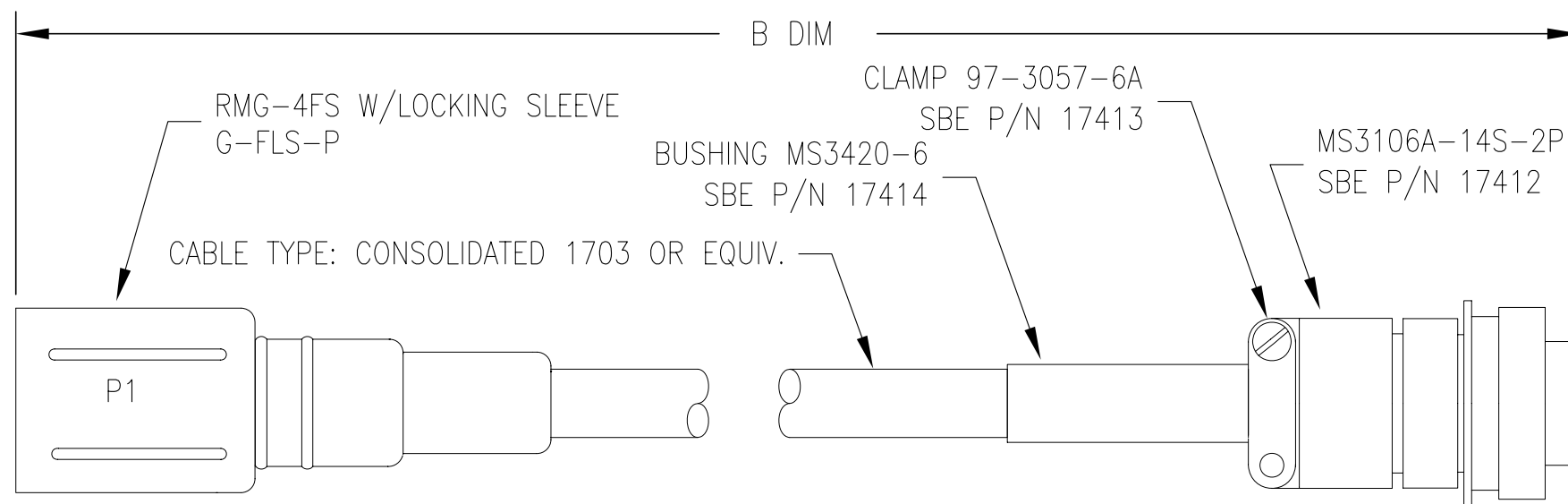
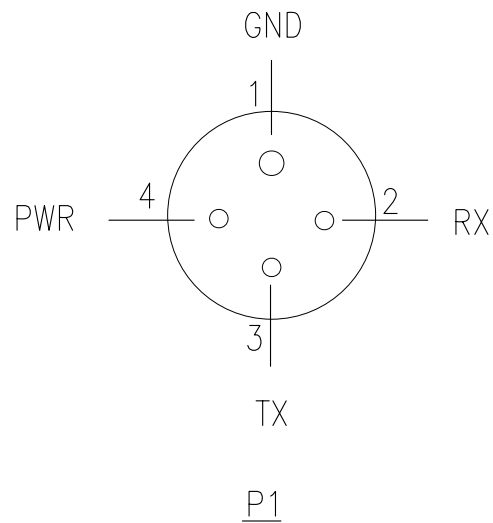

SBE 28 I/O, RMG-4FS TO MS CABLE ASSEMBLY					
SHIELDED ASSY P/N	PIGTAIL P/N	LENGTH		KEVLAR ASSY P/N	KEVLAR LENGTH
		'B' (FT)	'B' (m)		
80437 *	17031**	8	2.5		
80438	17204	33	10		
80455	17221	66	20		
80456	17232	100	30	80464	20 m
80457	17350	132	40	80465	30 m
80458	17351	165	50	80466	40 m
80459	17187	200	60	80467	50 m
80460	17148	330	100	80468	90 m
80461	17369	492	150	80469	140 m
80462	17244	660	200	80470	190 m
80463	17216	1500	455	80471	445 m
80693	17696	984	300		
80720	17723	500	152		
80755	17744	820	250		
	17640	363	110	80757	100 m
801050	17608	250	76	80801	61 m
80823	17614	462	140	80824	130 m
	17890	433	131	80843	121 M / #16 AWG
80941	17183	83	25		
-	17783	281	85	801037	75 m
801041	17340	120	36	-	-
801089	171194	174	53	-	-
801111	17230	50	15	-	-
-	171244	853	260	801113	250 m
801124	17477	17	5	-	-
801625	172157	10	3	-	-
801668	172200	13	4	-	-
801701	172278	220	67	-	-
801706	172283	40	12	-	-

WIRING CONNECTIONS			
P1	*COLOR 1	COLOR 2	P2
PIN 1	WHITE	SHIELD	A
PIN 2	BLACK	BLACK	B
PIN 3	GREEN	WHITE	C
PIN 4	RED	RED	D

* COLOR 1: 80437 ONLY
 COLOR 2: ALL OTHER

PIGTAILS ARE PURCHASED PER DWG 30585
 KEVLAR COATING PER DWG 20252
 ** P/N 17031 IS NOT SHIELDED AND DOES NOT REQUIRE THE BUSHING (17414)

TOLERANCES	SEA-BIRD ELECTRONICS, INC			
FRACTIONAL	P/N SEE TABLE	SCALE 1:1	DRAWN BY BMC	
DECIMAL	APPROVED BY KDL			
ANGULAR	DATE 4/3/91	DRAWING NUMBER 31063	REV B	
	TITLE UNIOPTOBOX DATA CABLE ASSY			