

DATE	SYM	REVISION RECORD	AUTH.	DR.	CK.
3.02	A	Redrawn on new template		LRG	
06.02	B	Add 17097, Step 5	CB	KLP	MJ
08.02	C	See ECN 726	DB	MJ	CB
9.23.02	D	ADJ. QTY & LENGTH	CB	KLP	
10.11.02	E	CHANGED BREAK STRENGTH	CB	KLP	
7.17.06	F	ECN 971, ALT WIRE COLOR	CB	CB	
9.6.2006	G	ECN 991 - Process Change	CB	MJ	

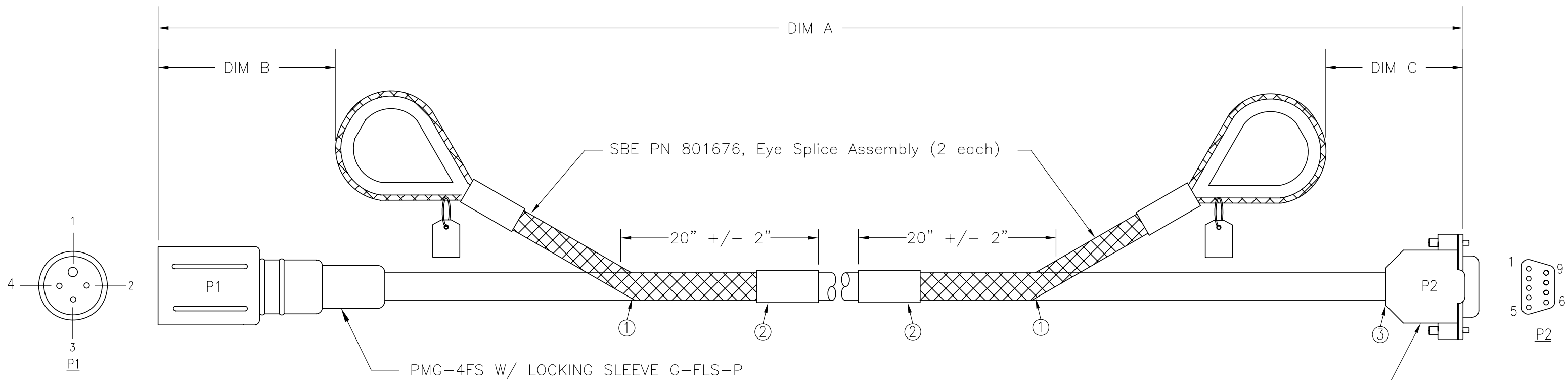

P1 PMG-4FS	COLOR	ALT COLOR	P2 DB-9S
PIN 1	WHITE	WHITE	PIN 5
PIN 2	WHITE/BLACK	BLACK	PIN 3
PIN 3	WHITE/RED	RED	PIN 2
PIN 4	--	--	--

SBE PN	PIGTAIL	DIM A		DIM B	DIM C
801140	171283	200 FT	60 m	52 IN	20 FT
801148	171301	600 FT	182 m	52 IN	20 FT
801150	171284	100 FT	30 m	52 IN	20 FT
801153	171306	330 FT	100 m	52 IN	20 FT
801293	171543	500 FT	152 m	52 IN	20 FT
801295	171551	165 FT	50 m	52 IN	20 FT
801301	171560	415 FT	125 m	52 IN	20 FT
801304	171581	83 FT	25 m	52 IN	20 FT
801307	171588	985 FT	300 m	52 IN	20 FT
801340	171654	528 FT	160 m	52 IN	20 FT
801352	171681	66 FT	20 m	52 IN	20 FT
801358	171690	660 FT	200 m	52 IN	20 FT
801514	172224	131 FT	40 m	52 IN	20 FT

DB-9S, SBE PN 17096  
HOOD, SBE PN 17097

CABLE TYPE: FALMAT  
SBE PN 171285, Pigtails per dwg 32275

FM020999SA1 REV. B  
POLYURETHANE, KEVLAR REINFORCED, 3 CONDUCTOR, 22 AWG.  
YELLOW JACKET, NOMINAL O.D. = 0.270 IN.  
100 LBS. WORKING LOAD (45 Kg)  
4 INCH MINIMUM BEND RADIUS (10 cm)

**BRAID AND LIFT-EYE INSTALLATION**

① BRING CABLE THROUGH BRAID  
20 +/- 2 INCHES BEHIND EYE

② 1/2" DIA. HEATSHRINK ADHESIVE TUBING 3", PN 31568

③ INSTALL CONNECTOR AFTER INSTALLING BRAIDED SPLICES

TOLERANCES	<b>SEA-BIRD ELECTRONICS, INC</b>			
FRACTIONAL	P/N	SCALE	DRAWN BY RMB	
	See Table	NTS	APPROVED BY	
DECIMAL	TITLE Load Bearing Data Cable PMG-4FS to DB-9S			
ANGULAR	DATE	DRAWING NUMBER	REV	
	4.26.99	32284	G	