

DATE	SYM	REVISION RECORD	AUTH.	DR.	CK.
03.02	A	Add Adhesive Tubing	MJ	CB	
8.29.02	B	CHANGED LENGTH	CB	KLP	
9.23.02	C	ADJ. QTY , LENGTH & PN	CB	KLP	
10.7.02	D	FIXED CONN DWG AND LS DESC	CB	KLP	
10.11.02	E	CHANGED CABLE BREAK STRENGTH	CB	KLP	
9.18.06	F	ECN 971 - COLOR CHANGE ECN 991 - PROCESS CHANGE	CB	MJ	

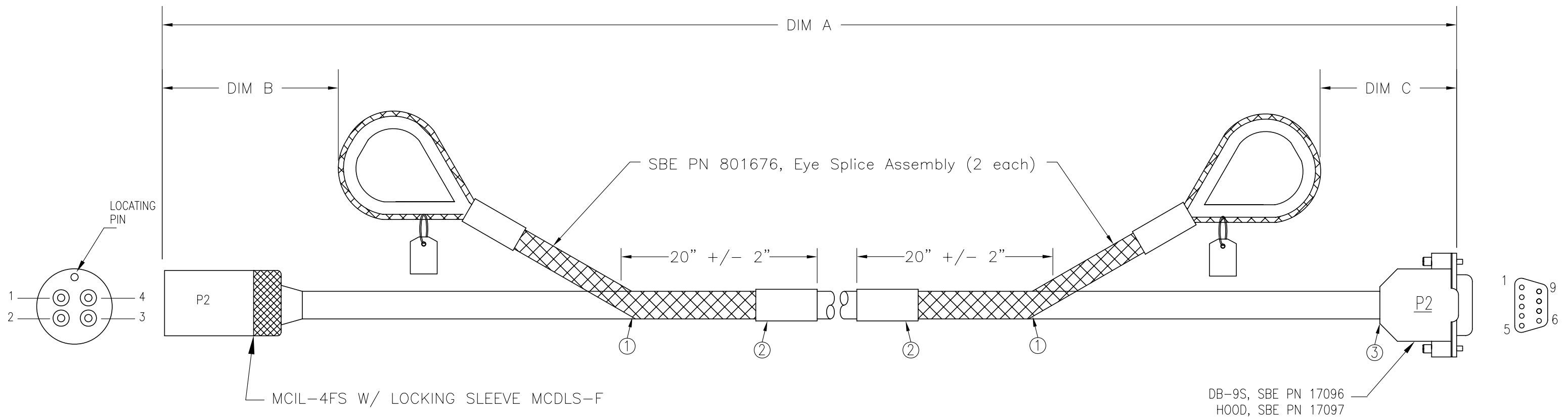

P1 MCIL-4FS	COLOR	ALT COLOR	P2 DB-9S
PIN 1	WHITE	WHITE	PIN 5
PIN 2	WHITE/BLACK	BLACK	PIN 3
PIN 3	WHITE/RED	RED	PIN 2
PIN 4	--	--	--

CABLE TYPE: FALMAT
 SBE PN 171285, Pigtails per dwg 32642

FM020999SA1 REV. B
 POLYURETHANE, KEVLAR REINFORCED, 3 CONDUCTOR, 22 AWG.
 YELLOW JACKET, NOMINAL O.D. = 0.270 IN.
 100 LBS. WORKING LOAD (45 Kg)
 4 INCH MINIMUM BEND RADIUS (10 cm)

BRAID AND LIFT-EYE INSTALLATION

- ① BRING CABLE THROUGH BRAID
20 +/- 2 INCHES BEHIND EYE
- ② 1/2" DIA. HEATSHRINK ADHESIVE TUBING 3", PN 31568
- ③ INSTALL CONNECTOR AFTER INSTALLING BRAIDED SPLICES

SBE PN	PIGTAIL	DIM A	DIM B	DIM C
801337	171633	330 FT	52 IN	20 FT
801338	171634	660 FT	52 IN	20 FT
801371	171707	100 FT	52 IN	20 FT
801372	171708	200 FT	52 IN	20 FT

SEA-BIRD ELECTRONICS, INC

P/N	SEE TABLE	SCALE	NTS	DRAWN BY	MJ
				APPROVED BY	
LOAD BEARING DATA CABLE MCIL-4FS					
DATE	9.18.2006	DWG NO.	32643	SHEET	1 of 1
				REV	F